

**NEW**

**PSM PRO SUBMERSIBLE MIXER**  
NEXT LEVEL MIXING

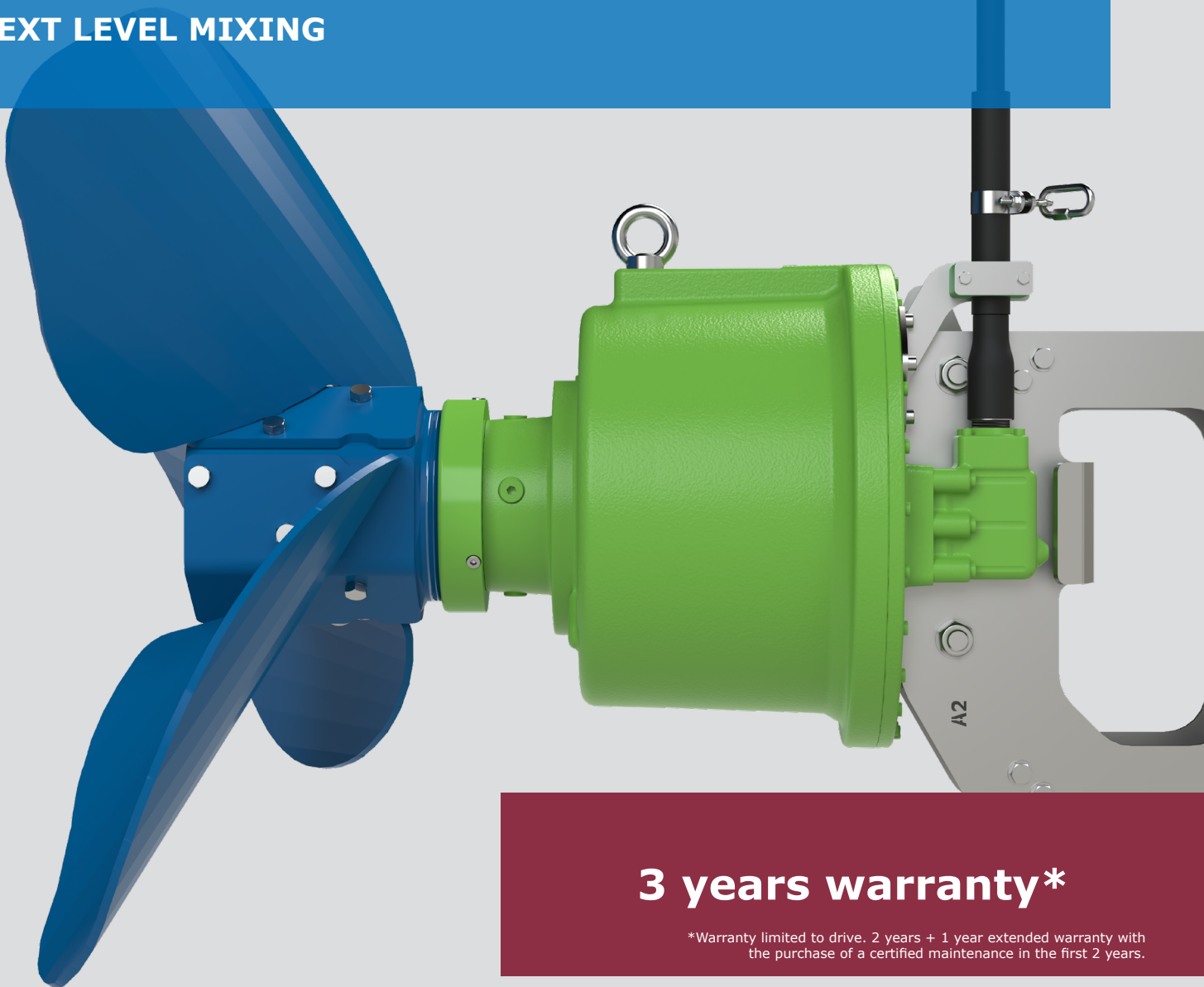

**3 years warranty\***

\*Warranty limited to drive. 2 years + 1 year extended warranty with the purchase of a certified maintenance in the first 2 years.

# THE NEW, IMPROVED PSM PRO SUBMERSIBLE MIXER

THINKING AHEAD FOR EVEN MORE EFFICIENCY AND QUALITY

The new PSM Pro is more than just a submersible mixer - it is an investment in the future sustainability of your biogas plant. An evolution of our proven PSM mixer, it offers maximum thrust with even greater efficiency, significantly improved quality and an even smarter product design. Depending on the viscosity of the mixed substrates, the PSM Pro handles digesters with up to 14% of dry matter.

The PSM Pro is also designed for the use with our self-developed DMC controller. The intelligent control of the optimized permanent magnet motor, in combination with our various 3D mixing blades, enables even greater cost savings. Compared to conventional "high-rpm-mixers" on the market, 50 % less power consumption, combined with a perfect homogenization, is achievable and provable.

Like earlier models, also the PSM Pro does not need a gear, which minimizes friction losses and eliminates a potential source of damage. The multi-sealed front bearing and the built-in leakage detection protects the motor from contamination and can be serviced quickly and cost-effectively. In addition to the improvements inside the agitator, the PSM Pro is also an overall upgrade in terms of product design with optimized sealing, reduced weight and a plug-in power and control cable. This enables a skilled person to replace the cable easily, in the event of a cable damage.

Decide on the new PSM Pro, boost your biogas production to the next level and reduce your costs to the maximum!

## Efficient:

Average power consumption of 5-9kW\*

## Strong:

Torque-motor with a lot of power even at low rpm  
800Nm Torque, 80-150 rpm and up to 14% DM Content

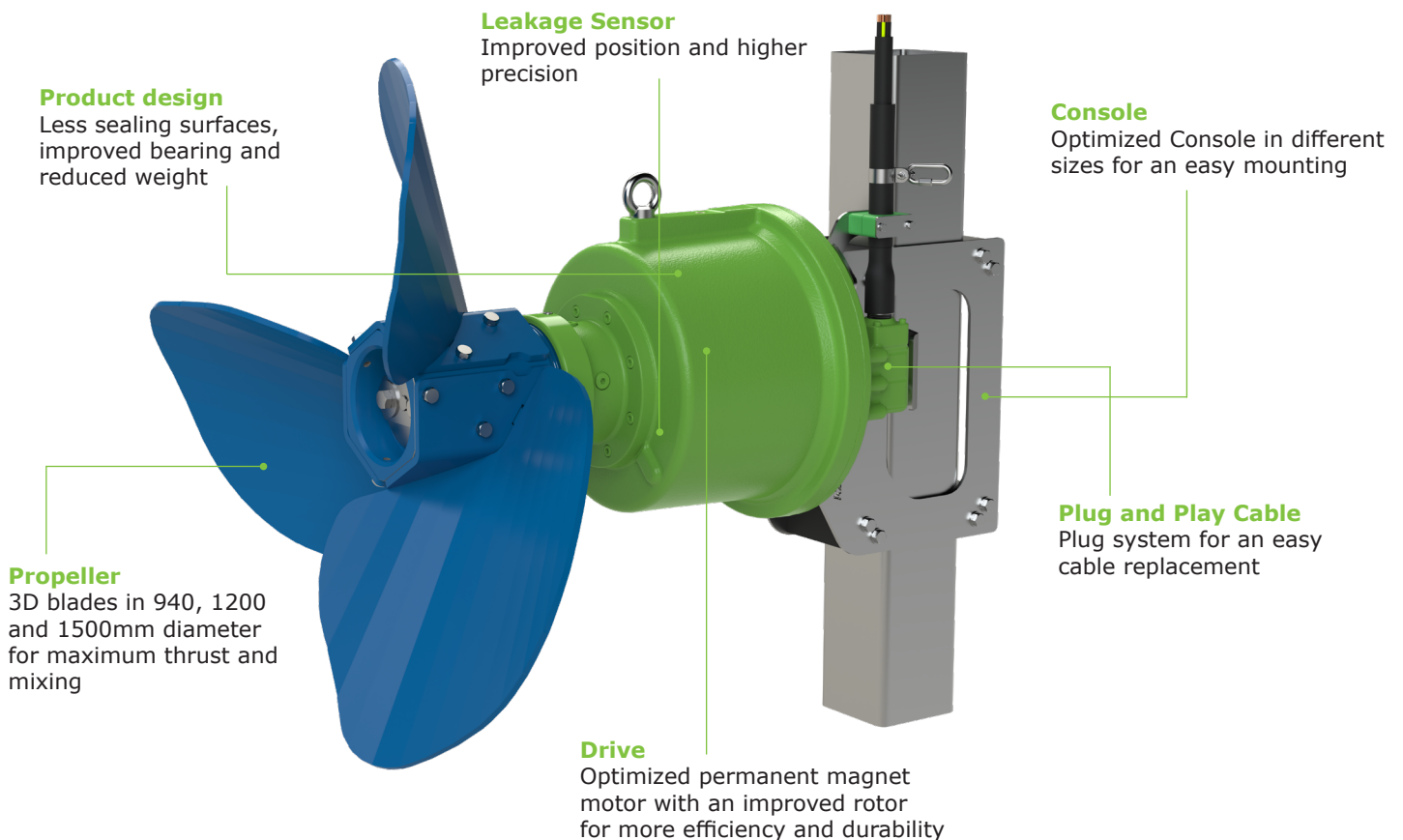

\*Values dependent on the substrate

## Safe:

ATEX and Cl. I, Div. 1 approved

## Intelligent:

DMC unit as mixing control

## Robust:

Gearless drive, high-quality components



**MIXER SERVICE ELEMENT (MSE) PRO**  
**SIMPLE OPERATION OF MIXERS IN BIOGAS**  
**PLANTS, WASTEWATER TREATMENT FACILITIES,**  
**AND INDUSTRIAL APPLICATIONS**

# BENEFITS AT A GLANCE

## SIMPLE CONTROL FOR EFFECTIVE MIXING

With our Mixer Service Element Pro, or MSE Pro, the operation of mixers from various manufacturers, in cylindrical concrete tanks with a wall height of up to 12 metres, is effortless. With the help of this external operating unit, you can easily rotate your mixer to the left and right or adjust its height. The clearance distance of approximately 1.80m from the tank wall allows flow paths behind the mixer to be optimized. An ideally mixed tank is the result.

The option to control mixers from the outside of the tank, without having to integrate it in membrane roofs, can be a good alternative to Anaergia's Service Box for many plant operators. The mixer position can be determined reliably at any time with the sensors, and the hydraulic drive enables unproblematic use in the gas storage space. With the elevated MSE Pro, the liquid level in the tank only has to be lowered slightly or not at all for maintenance purposes.

### EFFICIENT:

Quick manual adjustment of the mixer

### FLEXIBLE:

Integration without interfering with the enclosed membrane roof

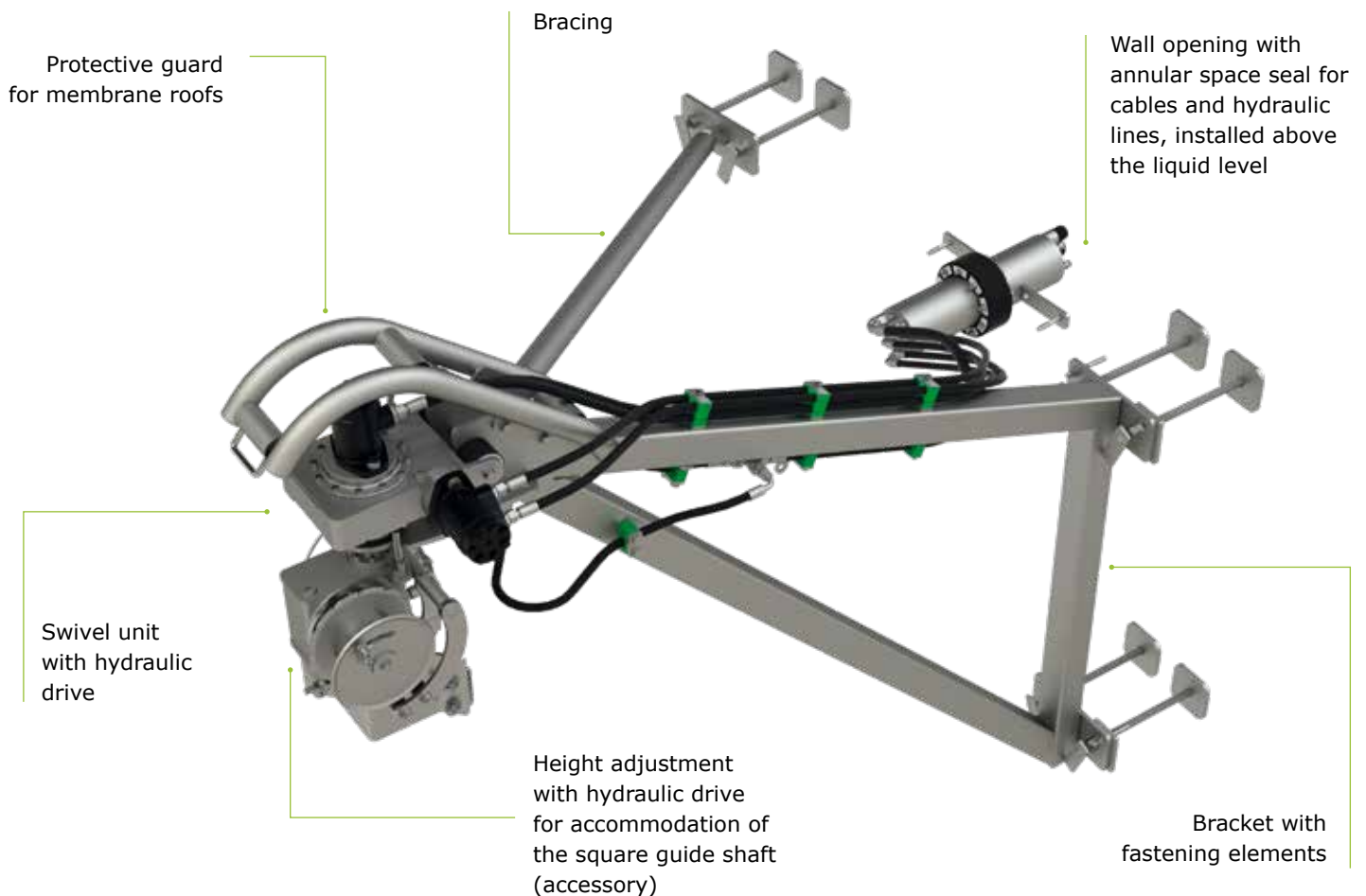

### SAFE:

Hydraulic drive enables use in the gas storage space

### INTELLIGENT:

Reliable location of the mixer position with use of sensors

### ROBUST:

Robust stainless-steel construction

# TWO-FINGER OPERATION

EASY, EASIER, MSE PRO

---

The hydraulic control unit makes it easy to change the position of the mixer. Levers on the control block can be used to adjust the height and to rotate the mixer to the left and right. A version with separate controls is also available as an alternative to the combined hydraulic control unit. With this option, the hydraulic unit can be installed at the bottom of the tank. The control unit can then be installed on a shelf near the viewing window at the top of the tank.

The position of the control unit can be adjusted to the local site conditions with various adjusting valves.



MSE PRO Hydraulic Control Unit



MSE PRO Control Unit



MSE PRO Hydraulic Unit

## OUR ANAERGIA TECHNOLOGIES

We offer solutions for the following applications:

- » Pump Technology
- » Mixing Technology
- » Separation
- » Extrusion Technology
- » Screening & Sorting
- » Size Reduction
- » Organic Polishing
- » Conveyor Technology



**Anaergia Inc.**  
**Headquarters**  
 Burlington, Ontario,  
 Canada  
 T: +1 905-766-3333

**Anaergia UK Ltd.**  
**Sales Office**  
 St. Neots, Cambs,  
 United Kingdom  
 T: +44 1480-477-608

**DB Technologies BV**  
**Product Company**  
 Oldenzaal, Netherlands  
 T: +31 541-745031

**Anaergia Technologies GmbH**  
**Product Company**  
 Lippetal, Germany  
 T: +49 2923-610940

**Anaergia OREX**  
**Manufacturing s.r.l.**  
**Product Company**  
 Ovada, Italy  
 T: +39 0143-835665

**Anaergia s.r.l.**  
**Sales Office**  
 TREVIGLIO, Italy  
 T: +39 0363-1970144

**Anaergia Services, LLC**  
**Sales Office**  
 Carlsbad, California,  
 United States  
 T: +1 760-436-8870

**Anaergia Africa (Pty) Ltd.**  
**Sales Office**  
 Cape Town, South Africa  
 T: +27 73 093 8328

**Anaergia Singapore Pte. Ltd.**  
**Sales Office**  
 Singapore  
 T: +65 6316-1575

### Anaergia Technologies GmbH

Oestinghausener Str. 12 · D-59510 Lippetal  
 T: (+49) 2923 / 610 940  
 www.anaergia-technologies.com

[info@anaergia.com](mailto:info@anaergia.com)

[www.anaergia.com](http://www.anaergia.com)



## PSM SUBMERSIBLE MIXER

MAXIMUM MIXING PERFORMANCE | MINIMUM ENERGY DEMAND



# BENEFITS AT A GLANCE

HIGH EFFICIENCY MOTOR THAT ACHIEVES EXCEPTIONAL MIXING PERFORMANCE AND LONG EQUIPMENT SERVICE LIFE

The PSM submersible mixer is the most innovative mixing technology currently available on the market. The powerful, gearless direct drive combined with the dynamic mixer controller delivers a mixing system that gets the most out of the energy it consumes. With electrical savings of 50 % or more, your facilities CO<sub>2</sub> footprint can be substantially reduced.

With permanent synchronous magnet (PSM) motor a gearbox is completely avoided and high torque is available as soon as the mixer starts. Fewer rotating

components, fewer failures, less costs. Not surprisingly, the PSM motor is also found in modern electric cars and delivers full torque right off the line. Therefore, floating layers and high solid digesters do not pose a problem for the PSM.

The 3D blade geometry has been designed using CFD modelling and has been improved and optimized to perfection with an ideal ratio of shear force and fluid flow. The result is consistently mixed digesters and bioreactors with maximum gas yield.

## EFFICIENT:

Average power input of 3 kW - 11 kW\*

## POWERFUL:

High torque motor with full power even at low speeds

Torque: up to 800 Nm

Speed: between 80 rpm and 150 rpm

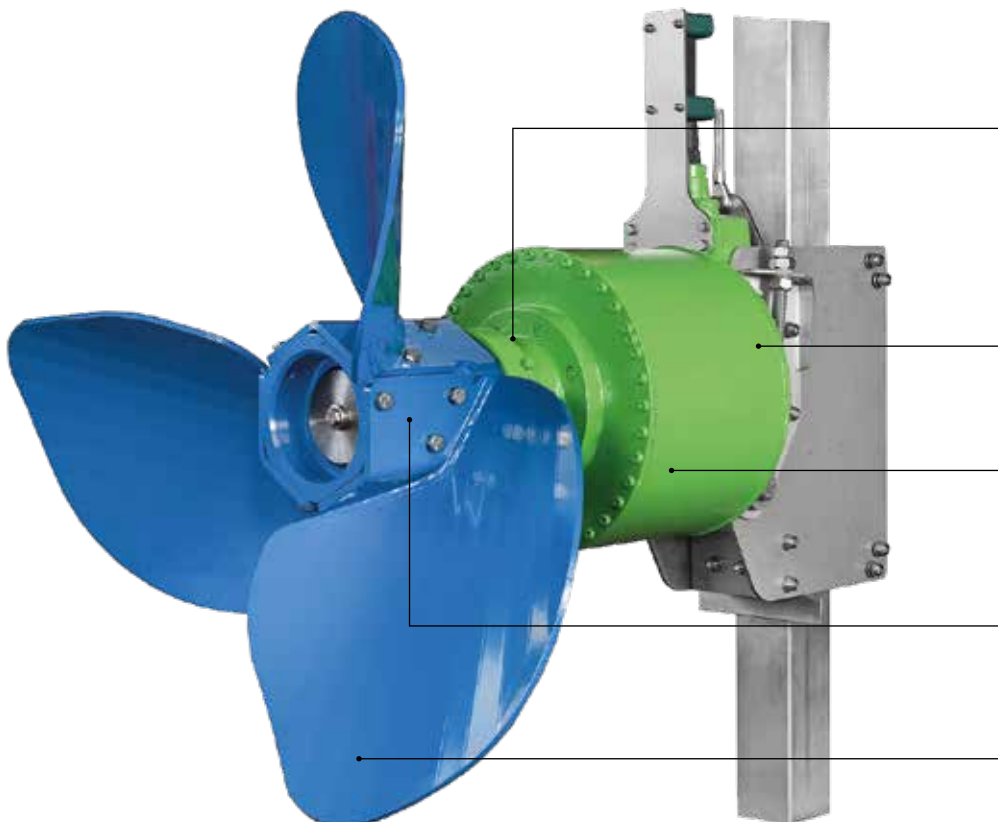

2 independent liquid seals prevent nuisance alarms and eliminate frequent maintenance. The first barrier is a pair of lip seals with flushless mechanical seal as a secondary protection

## State-of-the-art drive technology:

Powerful direct drive without gear unit

Robust explosion proof housing

Dedicated high thrust bearings independent of motor roller bearings

Optimized 3D propeller

## PROTECTED:

ATEX and Cl. I, Div. 1 Approved

## INTELLIGENT:

DMC control unit regulates everything automatically

## ROBUST:

Gearless drive, high-quality components

\* specified values depend on the medium

# THE MULTITASKER

## PSM SUBMERSIBLE MIXER

### HOMOGENIZED SLURRIES

- » Effective mixing of slurries even with high total solids content of up to 12 % and more\*
- » Less dilution of substrate required = improvement in retention time = less storage volume

### MIXING OF FLOATING SCUM LAYERS AND SETTLED GRIT

- » High mixing power and thrust prevent grit from settling and floating scum layers from forming even in high solids digesters
- » More operating reserves for biogas plants / high motor torque of up to 800 Nm

### DISSOLVING OF LARGER SOLIDS

- » Supporting the biological process in the conversion of fiber-rich input materials
- » With the help of the flow generated by the steel propeller, even large amounts of solids can be agitated

### MAXIMIZE DIGESTER ACTIVE VOLUME

- » Maintain high active volume by eliminating dead zones
- » Innovative blade geometry creates effective flow for constant gas exchange, which is critical for bacteria

### SAFE AND FLEXIBLE USE

- » Efficient monitoring of the electric motor with the assistance of the DMC (temperature, power consumption, speed, torque)
- » Protection for both Class I, Division 1, Group D, T3C and ATEX II 2 G Ex e IIA T1 Gb

### LOW OPERATING AND MAINTENANCE COSTS

- » Reduction of mixing times and power consumption by adapting speed and thrust to the viscosity of the medium
- » Energy-efficient mixing due to Dynamic Mixer Controller (an intelligent VFD)
- » No gear unit = less wear = longer service life of the mixer



PSM-940



PSM-1200



PSM-1500

## AREA OF APPLICATION

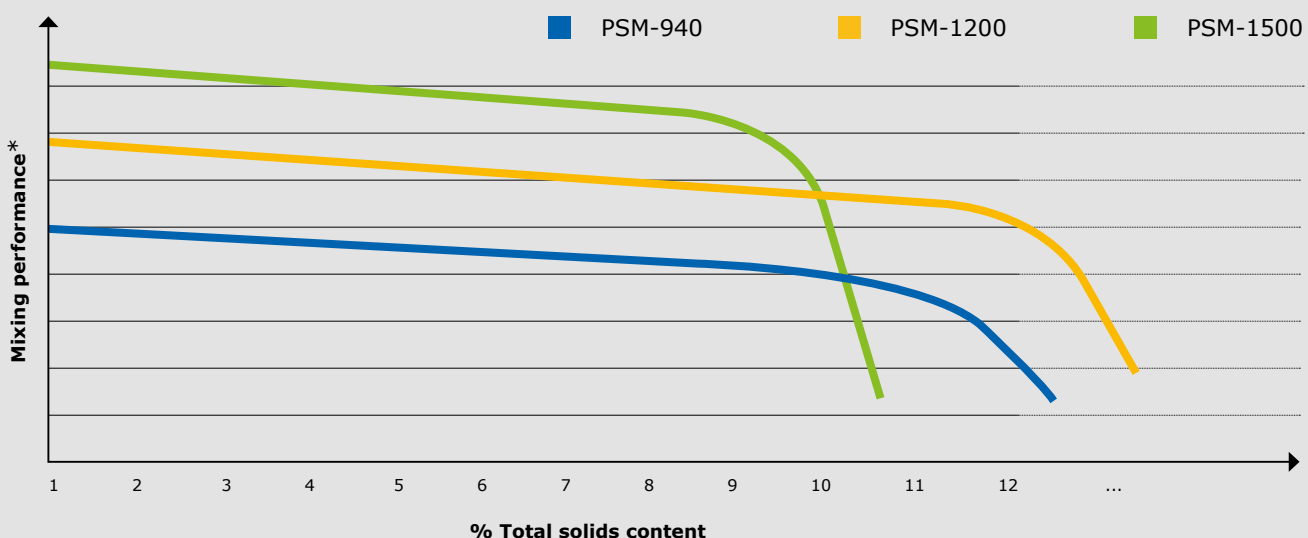

# PSM INSTALLATION EXAMPLE

FLEXIBLE MIXING FOR YOUR TOUGHEST APPLICATIONS



The PSM submersible mixer is suitable for installation in all common tanks. The bracket is designed for standard square guide posts with a 6 inch (150 mm) width but can also be installed with other square guide tube dimensions using bracket adapters. This makes it possible to integrate the mixer into a wide range of different biogas plants or wastewater treatment plant anaerobic digesters or anoxic tanks.

With the PSM, you bring mixing power, shear force and energy efficiency to your tank with a reliable, proven design.

Of course, in addition to the mixer, we also offer custom mixing equipment and installation solutions.

## **PSM + Service Box:**

Our Service Boxes Classic and Pro are equipped with an integrated mixer post pivoting bracket and a gas lock service opening. Therefore, the mixer can be adjusted in height and swivelled to the left and right in order to mix the contents of the entire tank.

## **WHICH PSM MIXER BLADE SUITS YOUR PLANT?**

### **PSM-940**

- » For mixing of solids / substrates with medium dry matter content
- » Suitable for use in Newtonian (water-like viscosity) as well as viscous fluids
- » Creates a turbulent flow due to the higher speed and geometry of the mixer blade

### **PSM-1200**

- » For mixing substrates with a medium to high dry matter content
- » The geometry of the mixer blade is designed for thrust development in viscous and highly viscous fluids
- » Generates a higher volume flow than the PSM-940 at a lower speed due to the mixer blade geometry

### **PSM-1500**

- » For mixing substrates with a low dry matter content
- » Suitable for use in low-viscosity fluids
- » Lower speed than the PSM-940, but also a higher volume flow due to the blade geometry

# INTELLIGENT MIXING

FOR EVEN GREATER COMFORT

The **DMC** (Dynamic Mixer Controller) is our control unit developed exclusively for the PSM. It expands the possibility of the PSM and takes full advantage of output power and energy efficiency.

The DMC regulates the PSM according to the operator's needs or the requirements of the mixing application. For example, it is possible for the system to operate at constant speed or at constant torque. With a constant speed setting, the power input fluctuates depending on the torque.

If, by contrast, a torque value is specified, the speed of the mixer varies within a certain range and continuously

delivers high thrust mixing to the tank's slurry. In the process, the power input remains at a constant level. This all takes place fully automatically without intervention by the operator.

The DMC also outputs data and allows for insightful understanding of the mixing process. This allows the operator to quickly "see" the performance of the digester and how changes in substrate affects the process.

The DMC can be connected to the plant level PLC via an analogue signal, Profibus or Profinet connection. Fully integrated local control panels are also available complete with a touchscreen operator interface.

## INSTALLATION EXAMPLE FOR THE PSM MIXER:



Plant PLC



Mixer cable

PSM terminal box  
PSM maintenance switch

Leak probe (intrinsically safe cable)

PTC (intrinsically safe cable)

Disconnect switch control cable

DMC control signals

Power cable

## OUR ANAERGIA TECHNOLOGIES

We offer solutions for the following applications:

- » Pump Technology
- » Mixing Technology
- » Separation
- » Extrusion Technology
- » Screening & Sorting
- » Size Reduction
- » Organic Polishing
- » Conveyor Technology



**Anaergia Inc.**  
**Headquarters**  
 Burlington, Ontario,  
 Canada  
 T: +1 905-766-3333

**Anaergia UK Ltd.**  
**Sales Office**  
 St. Neots, Cambs,  
 United Kingdom  
 T: +44 1480-477-608

**DB Technologies BV**  
**Product Company**  
 Oldenzaal, Netherlands  
 T: +31 541-745031

**Anaergia Technologies GmbH**  
**Product Company**  
 Lippetal, Germany  
 T: +49 2923-610940

**Anaergia OREX**  
**Manufacturing s.r.l.**  
**Product Company**  
 Ovada, Italy  
 T: +39 0143-835665

**Anaergia s.r.l.**  
**Sales Office**  
 Treviglio, Italy  
 T: +39 0363-1970144

**Anaergia Services, LLC**  
**Sales Office**  
 Carlsbad, California,  
 United States  
 T: +1 760-436-8870

**Anaergia Africa (Pty) Ltd.**  
**Sales Office**  
 Cape Town, South Africa  
 T: +27 73 093 8328

**Anaergia Singapore Pte.**  
**Ltd.**  
**Sales Office**  
 Singapore  
 T: +65 6316-1575

### Anaergia Technologies GmbH

Oestinghausener Str. 12 · D-59510 Lippetal  
 T: (+49) 2923 / 610 940

[www.anaergia-technologies.com](http://www.anaergia-technologies.com)



## UTS PUMPS

**PROVEN TECHNOLOGY FOR USE IN BIOGAS  
PLANTS AND IN SLURRY-, WASTEWATER-  
AND INDUSTRIAL APPLICATIONS**

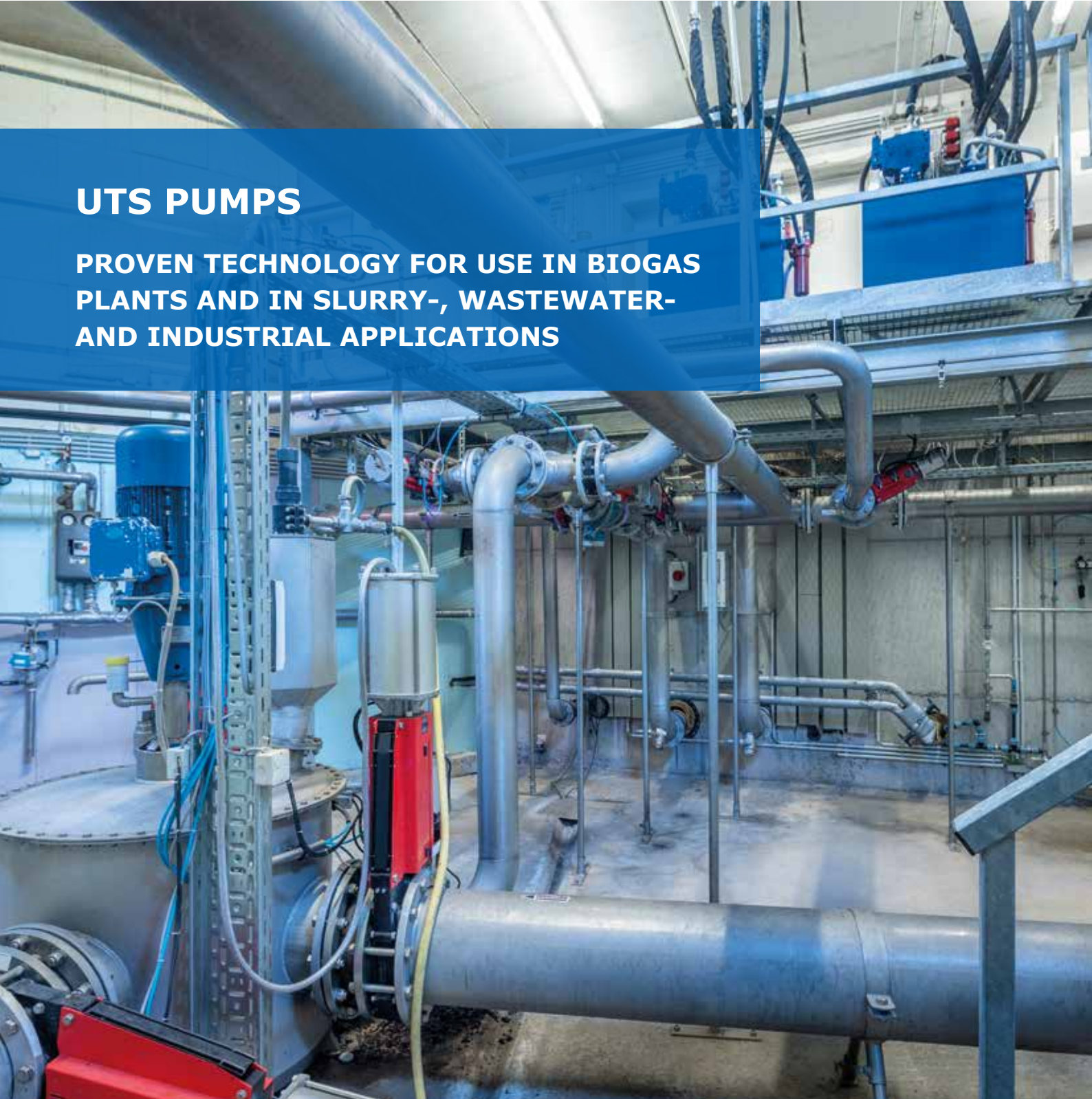

Central pump station

# BENEFITS AT A GLANCE

TRANSPORT. CHOP. AGITATE.

Pumps have been a part of our core assortment since 1992. Our robust models are all designed so that they do what they are supposed to even under the most difficult of conditions: pump, pump, pump. And that's not all. In order to be able to transport especially thick and fibrous media in a safe and controlled manner, such as slurry or digestate in biogas plants, our pumps (4000 series) also tear and cut.

Based on their design, our pumps are unsusceptible to foreign objects, feature impressively low maintenance expenses, and minimize life cycle costs with an extremely low failure probability. This is thanks to the multi-

bearing drive shafts running in an oil bath, the shaft slide-ring seal with an oil vessel for protection against dry runs, as well as the specially designed spiral housing that is resistant to clogging.

Our pump series are available with various drive types and can also be used with large tank depths.

Configuration always takes place on an individual basis according to the requirements of the relevant application. In doing so, we ensure that the selected pump not only delivers the optimal output, but also provides an impressive service life.

## RELIABLE:

Delivery rates of up to 300m<sup>3</sup>/h (3000 series) or 360m<sup>3</sup>/h (4000 series) and a maximum pressure of 4.5 bar (4000 series)

## FLEXIBLE:

Numerous configuration possibilities, adapted to individual requirements

## PUMP SERIES 3000

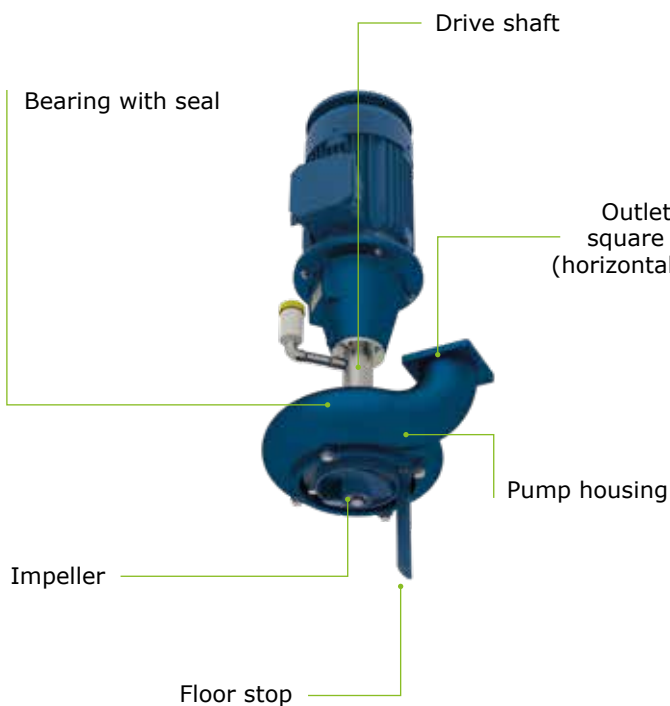

## PUMP SERIES 4000

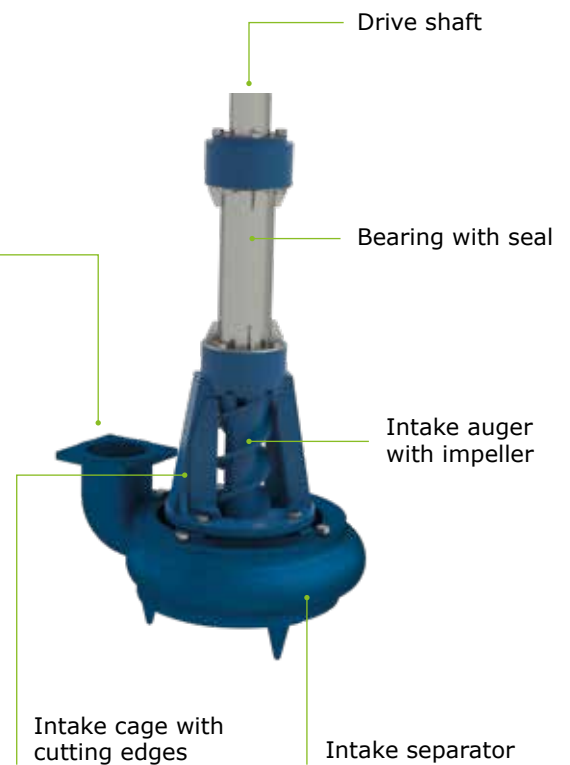

## LONG-LASTING:

Unsusceptible to foreign objects or dry runs

## SAFE:

Resistant to clogging thanks to effective cutting performance, among other features

## ROBUST:

Sturdy cast iron and steel construction

# PUMP SERIES 3000 AND 4000

YOU CAN COUNT ON THESE PUMPS

## 3000 SERIES

### APPLICATIONS

- » Agriculture: Slurry technology, mobile and stationary pump systems
- » Wastewater & sewage treatment plants: Faecal sludge, digested sludge, primary sludge
- » Food industry: Vegetable processing, slaughterhouses

### GENERAL TECHNICAL FEATURES FOR ALL PUMPS IN THE 3000 SERIES

- » Pump housing intake from below
- » Transportation and homogenization of fluids with a proportion of solid and fibre material up to 8% TS
- » Free-flow impeller with WIDIA carbide cladding on cutting and wear edges

## 4000 SERIES

### APPLICATIONS

- » Agriculture: Slurry technology, mobile and stationary pump systems, biogas plants
- » Wastewater & sewage treatment plants: Faecal sludge, digested sludge, primary sludge
- » Food industry: Vegetable processing, slaughterhouses

### GENERAL TECHNICAL FEATURES FOR ALL PUMPS IN THE 4000 SERIES

- » Feed via helical intake from above
- » Transportation and homogenization of fluids with a proportion of solid and fibrous material up to 12% TS
- » Free-flow impeller with WIDIA carbide cladding on cutting and wear edges
- » Non-clogging spiral housing, specially designed to accommodate thick and dense media
- » Double-action slide-ring seal with oil vessel in industrial standard quality

# WIDE-RANGING DESIGNS – CONSTANT PERFORMANCE

PUMPS FOR EVERY APPLICATION

## LONG-SHAFT PUMPS

The advantage of this design is in the extended drive shaft. It makes it possible to position the pump body on the bottom of the tank. The motor and operating lever are easily accessible outside of the tank for easy operation and electrical maintenance. A mixing nozzle can also be integrated into the standpipe (pressure side) to mix the substrate before it is pumped out. The control rod switches using a 3-way valve. The standpipe output can be arranged directly upwards or laterally through the tank wall.

### HIGH-PERFORMANCE CHOPPER MIXING PUMP HRP 3000 E/S

- » Long-shaft pump with pump housing intake from below
- » Multi-bearing drive shaft running in an oil bath
- » Performance classes: 5.5kW to 22kW

### PRESSURE CHOPPER MIXING PUMP DRP 4000 E/S

- » Long-shaft pump with helical intake (combined with free-flow impeller)
- » Multi-bearing drive shaft running in an oil bath
- » Performance Class: 7.5kW to 30kW

## SUBMERSIBLE PUMPS

Submersible pumps are distinguished by their compact design. The motor is submerged with the pump housing, and can be lowered and raised on a rope using a guide pipe. In addition to a hoisting device, we recommend installation with a base frame and snap-on claws.

### HIGH-PERFORMANCE CHOPPER MIXING PUMP HRP 3000 E/T

- » Submersible pump with pump housing intake from below
- » Performance classes: 5.5kW to 18.5kW

### PRESSURE RIP-MIX PUMP DRP 4000 E/T

- » Submersible pump with intake auger on the pump body
- » Performance classes: 7.5kW to 22kW



HRP 3000E

DRP 4000E



DRP 4000E/T

# WIDE-RANGING DESIGNS – CONSTANT PERFORMANCE

PUMPS FOR EVERY APPLICATION

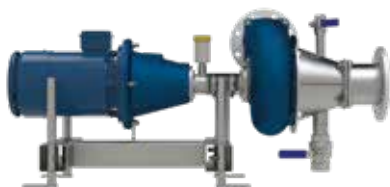

RPM 3000

## INSTALLATION DIRECTLY IN THE PIPELINE

Our pump is directly integrated into the pipeline. This ensures especially efficient delivery of the substrate as long as a free flow of substrate is provided. This type of pump is particularly advantageous for drum filling stations.

### PIPE PUMP MATIC RPM 3000 E

- » Pump with surface motor and pump housing with front end intake
- » Special design with pump housing intake from below also available
- » Performance classes: 5.5kW to 22kW



RPM 4000

### PIPE PUMP MATIC RPM 4000 E

- » Dry-installed pump in closed design for reduced noise emissions
- » Centrifugal pump with external drive
- » Performance classes: 11kW to 22kW

## CENTRAL PUMP STATION

The central pump station was developed to distribute media between the tanks of a biogas plant quickly and efficiently. It is ideally located in a building arranged centrally between the tanks. Then the pump station is connected to each tank with the appropriate pipelines. In the process, the substrate can be pumped from a digester to a secondary digester or storage tank as necessary. The pump paths can be adjusted flexibly with suitable knife gate valves.

High throughputs ensure that relatively little time is needed for pumping. The optionally available speed control unit also minimizes energy consumption and wear during day-to-day operation. In addition, a manual or automatic venting device is available for gas-laden media. Our central pump station is only available in combination with an internal pump in the 4000 Series.



ZPS 4000

### CENTRAL PUMP STATION ZPS 4000 E

- » Dry-installed central pump station for various delivery modes, with a collector tank and multi-option ports for fully-automatic substrate management
- » Centrifugal pump with external drive
- » Performance classes: 11kW to 30kW

## OUR ANAERGIA TECHNOLOGIES

We offer solutions for the following applications:

- » Pump Technology
- » Mixing Technology
- » Separation
- » Extrusion Technology
- » Screening & Sorting
- » Size Reduction
- » Organic Polishing
- » Conveyor Technology



**Anaergia Inc.**  
**Headquarters**  
 Burlington, Ontario,  
 Canada  
 T: +1 905-766-3333

**Anaergia UK Ltd.**  
**Sales Office**  
 St. Neots, Cambs,  
 United Kingdom  
 T: +44 1480-477-608

**DB Technologies BV**  
**Product Company**  
 Oldenzaal, Netherlands  
 T: +31 541-745031

**Anaergia Technologies GmbH**  
**Product Company**  
 Lippetal, Germany  
 T: +49 2923-610940

**Anaergia OREX**  
**Manufacturing s.r.l.**  
**Product Company**  
 Ovada, Italy  
 T: +39 0143-835665

**Anaergia s.r.l.**  
**Sales Office**  
 Treviglio, Italy  
 T: +39 0363-1970144

**Anaergia Services, LLC**  
**Sales Office**  
 Carlsbad, California,  
 United States  
 T: +1 760-436-8870

**Anaergia Africa (Pty) Ltd.**  
**Sales Office**  
 Cape Town, South Africa  
 T: +27 73 093 8328

**Anaergia Singapore Pte. Ltd.**  
**Sales Office**  
 Singapore  
 T: +65 6316-1575

### Anaergia Technologies GmbH

Oestinghausener Str. 12 · D-59510 Lippetal T: (+49) 2923 / 610 940

[www.anaergia-technologies.com](http://www.anaergia-technologies.com)



## SEPARATOR FSP, MSU, MSU LIGHT AND MSU PRO

MAXIMUM SEPARATION | MINIMUM OPERATION COSTS



# BENEFITS AT A GLANCE

## UNCOMPROMISING QUALITY

For more than 15 years, we have been developing and manufacturing filter screw press (FSP) separators that provide consistently high separation and throughput performance with a very long service life. Additionally, with high quality standards and innovative detailed solutions, there is a very low maintenance requirement for the unit.

The hinged, quick-release press housing offers easy access to the screen and screw, while the inspection openings in the inlet and screen housing make cleaning and maintenance work quick and easy.

The auger used in our separators has tungsten carbide cladding. This makes it extremely hard, precise and wear-resistant.

The fibre cutting function upstream from the screen area ensures that long fibrous materials are unable to cause clogging.

With our wide range of models, we can go over your individual requirements and offer you a solution that best suits your application, whether for agriculture or industry.

### ROBUST:

Durable cast iron (FSP B) or stainless steel (FSP A) housing

### EFFICIENT:

High separation and throughput performance with low energy consumption and wear

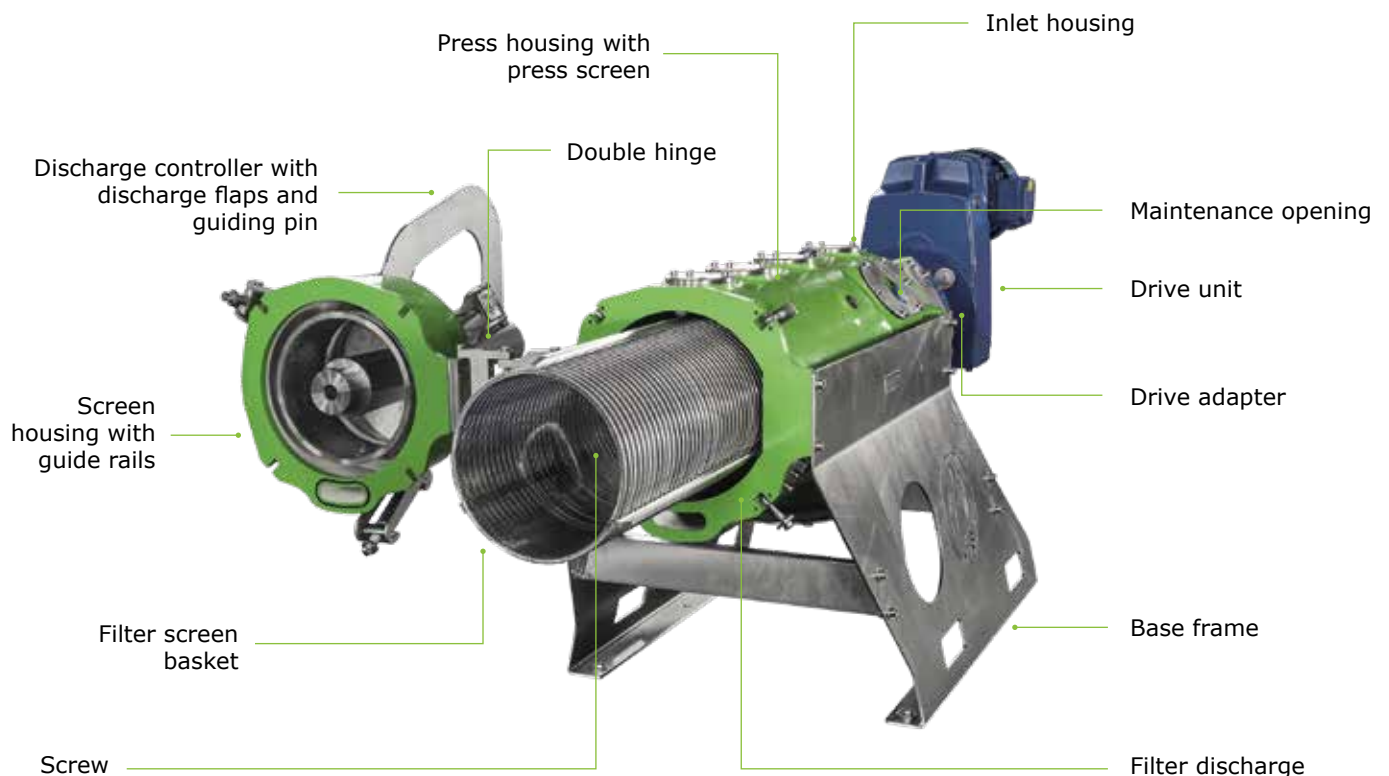

### PROTECTED:

Drive adapter protects the gear unit

### INTELLIGENT:

Quick access options for maintenance work

### FLEXIBLE:

Wide range of models enables versatile use

# A UNIQUE TECHNOLOGY

## FSP SEPARATORS

---



### SEPARATION OF FILTER AND PRESS AREA

Maximize the capacity, minimize the wear.

- » Radially moving filter screen head is separated from the high-pressure-resistant press screen basket by a fixed wear ring made of a specially selected plastic
- » Screw flights end at the wear ring
- » No pressure is exerted on the filter screen basket by the press. As a result, the entire screen surface area is available for dewatering



### FOLDING PRESS HOUSING WITH QUICK-RELEASE

Quick access to screen and screw without excessive physical effort.

- » Screw press housing with press screen basket, and discharge controller with spring flap mechanism can be opened with the quick-release mechanism and folded back with sturdy hinges
- » Screw and screen can be easily removed without prior removal of the plug of solid material



### SCREW PRESS WITH TUNGSTEN CARBIDE CLADDING

Stability, maximum precision, and extremely high wear resistance.

- » Dual-threaded screw press with vane thickness of 10mm over the entire spiral length
- » Highly wear-resistant, precisely-ground tungsten carbide cladding over the entire screen region



### INSPECTION OPENINGS IN THE INLET AND SCREEN HOUSING

Quick access to the screen surface and screw connection with disassembly of the supply line.

- » Inspection openings in the inlet and screen housing enable quick access for cleaning, maintenance and monitoring purposes



### DRIVE ADAPTER WITH SLIDE RING SEAL AND SEALED CHAMBER

No gear damage due to penetration of water or application of axial forces.

- » Connection of the screw facilitated by the drive adapter with high-quality bearing, slide ring seal, and sealed chamber



### FIBRE CUTTING FUNCTION BEFORE ENTRY INTO THE SCREEN REGION

No clogging due to long fibrous material.

- » Wear plates with slotted shearing holes (FSP A) or cutting bars (FSP B) in the inlet housing
- » Replaceable screen guide ring with cutting function immediately upstream of the screen inlet

# INSTALLATION EXAMPLE: SEPARATORS FSP A AND B

Our separators are designed to be extremely robust and are thus consistently manufactured for difficult applications. In the process, the highest possible throughput is achieved for the separation of manure, digestate, mash, and other substances.

Maintenance and service tasks can be carried out quickly and easily on-site without disassembly of the press head and pipelines – reducing overall downtimes to a minimum.

An important element of our service is providing an individual design for every project through the use of a mass, nutrient, and cost balance.

This provides you with exactly the right solution that optimally suits your application with respect to performance requirements and costing. Upon request, we can take care of the complete separator installation for you, including the platform, control unit, pipeline installation, pumps, fittings and sensors.



# EVERYTHING IS POSSIBLE

## SEPARATOR APPLICATIONS

### FSP A SEPARATOR

We have developed our FSP A stainless steel separator series based on the very high requirements of industry and high-performance agriculture. Typical areas of application include:

- » Paper, pulp and wood-processing industry (e.g. MDF): Dewatering of pulp, rejected fine material and fibrous sludges, as well as fibre extraction from wastewater and process water.
- » Food industry: Fruit and vegetable processing, dewatering of distiller's wash and mash, wastewater and waste treatment
- » Meat processing industry: Slaughter waste, stomach and intestinal content, wastewater
- » Recycling of plastics: Separation of waste, cleaning of wastewater and circulation water

### FSP B SEPARATOR

The FSP B series is an attractive, affordable alternative to the FSP A particularly for agricultural applications. The two series are identical in terms of design and function. However, FSP B components like the inlet, screen, and press housing are intrinsic components made of affordable cast iron. Typical areas of application include:

- » Separation of cattle, pig and poultry liquid manure
- » Separation of digestate from biogas plants to reduce the storage volume (10-30 %)
- » Meat processing industry: Slaughter waste, stomach and intestinal content, wastewater

### BEDDING SEPARATORS

The bedding series consists of especially powerful separators to produce bedding material for dairy farming. With the separation of screen and press areas, this model has the ideal design for the generation of high compression pressure. With reduction of the screw speed and the use of high-torque drives, reinforced screens, and a modified back-pressure device, high total solids (TS) percentages of 30–40 % are achieved.

- » Cost-effective in-house production of dry bedding material from cattle manure
- » No costly purchasing of box bedding material, such as straw or sawdust
- » Increased lying comfort and better udder health
- » Cleaner animals with good water-binding capability of the "mattress"
- » Easier distribution of the separated manure (liquid phase) and increased capacity in the manure storage

MODEL RANGE		(Values dependent on the input)		
FSP Model	Digestate / Cattle Manure		Liquid Pig Manure	
	Throughput	Total Solids (%)	Throughput	Total Solids (%)
FSP A & B-52/10	10-25 m <sup>3</sup> /h	22-25 %	18-30 m <sup>3</sup> /h	25-35 %
FSP A & B-52/15	10-25 m <sup>3</sup> /h	22-28 %	18-30 m <sup>3</sup> /h	25-40 %
FSP A & B-78/10	15-35 m <sup>3</sup> /h	22-25 %	25-45 m <sup>3</sup> /h	25-35 %
FSP A & B-78/15	15-35 m <sup>3</sup> /h	22-28 %	25-45 m <sup>3</sup> /h	25-40 %
FSP A-104/15	25-45 m <sup>3</sup> /h	22-28 %	35-60 m <sup>3</sup> /h	25-40 %
FSP A & B-52/15 Bedding	5-10 m <sup>3</sup> /h	30-35 %		
FSP A & B-78/15 Bedding	8-15 m <sup>3</sup> /h	33-40 %		

# OUR COMPACT SEPARATION

## CONNECT AND START

For those who are looking for an uncomplicated and cost-effective separation system, but do not want to compromise on quality, our new MSU light is the right choice.

This compact separation unit is a smart plug & play solution that has everything you need for a quick and easy separation of liquid manure or digestate.

The MSU light is equipped with the FSP B 52/15 screw press that features independent press head and dedicated drive adapter. The selection of high-quality components, such as the NETZSCH Nemo progressive cavity pump, also contribute to a smooth operation.

The MSU light offers a perfect price-performance ratio, especially for smaller farms. As an example for the "keep it simple" approach, the slurry pressure is regulated with the help of an overflow pipe, instead of additional control technology.

The filtrate is discharged through an outlet directly into the extraction pit or into a storage tank. The resulting press cake with approx. 28 % dry matter is ejected at a height of 1.30 m and can be loaded with a front loader or similar. A plate serves to protect the technology when pushing and loading the press cake. The forklift pockets ensure an easy transport of the transportation of the unit.

### MOBILE:

Light weight, easy to transport

### EFFICIENT:

High separation and throughput performance with low energy consumption and wear

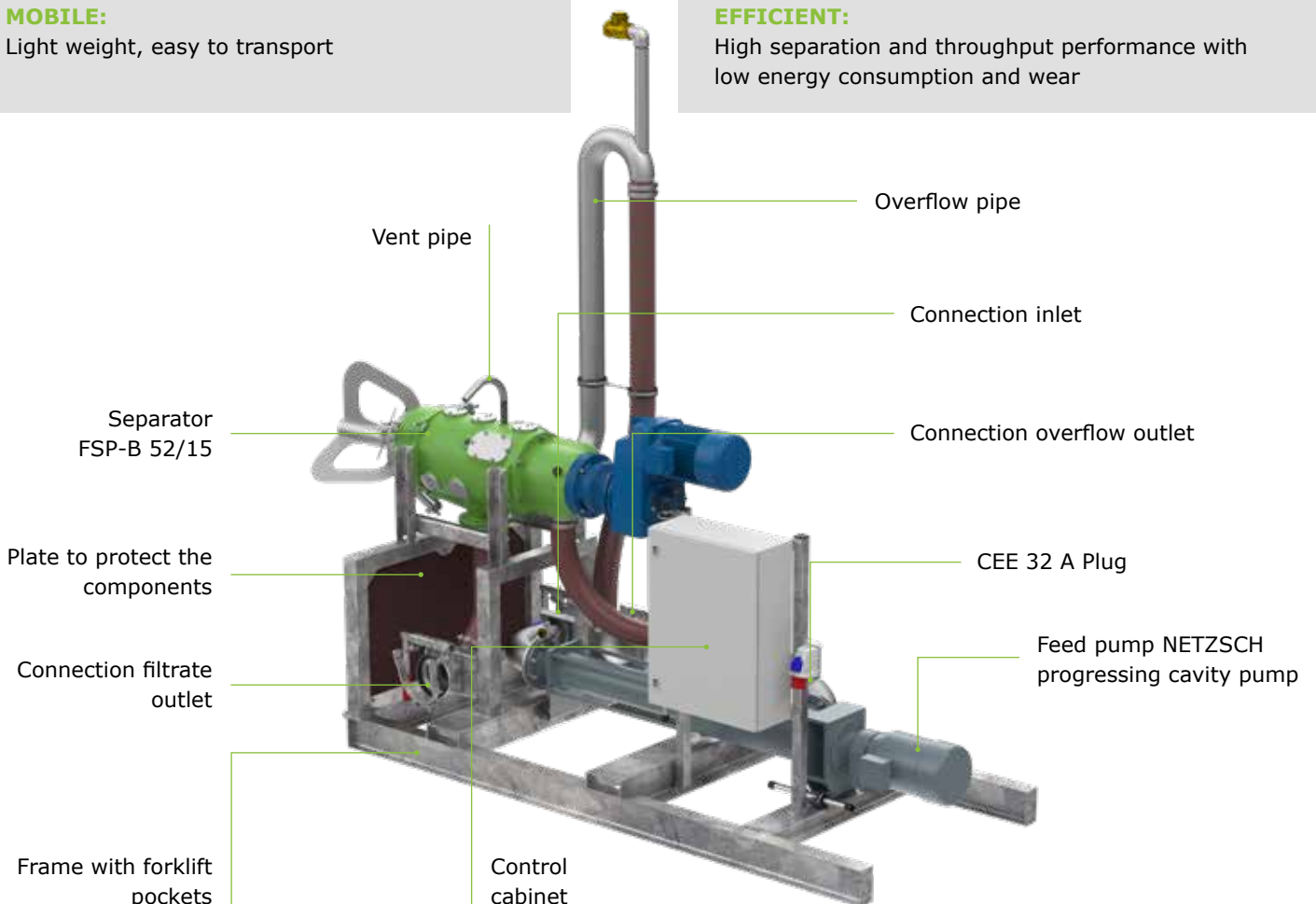

### ROBUST:

galvanized steel frame, stable construction, high-quality components

### FLEXIBLE:

Sharable, rentable and no permitting required

### MODIFICATION:

Use with 28 % dry matter or bedding variant with 35 % dry matter

# MOBILE SEPARATION SERVICE WITH THE MSU

## UNCOMPLICATED PLUG & PLAY-SOLUTION

The MSU (Mobile Separation Unit) is a compact plug & play-solution for flexible separation of slurry and digestate.

This unit is ideal for you if you want to separate slurry and digestate at different locations on your farm. It can also be worthwhile for small and medium-sized neighboring farms to operate a mobile separator together and thus save costs. Of course, the MSU can also be rented out - the optional flow meter helps you with billing.

Plug & Play means: simply connect and operate with a flow rate of up to 45 m<sup>3</sup>/h. This is made possible by a

constantly regulated inlet pressure that ensures optimized material feed. The compact arrangement of the entire unit allows easy transport, e.g. by trailer.

Depending on the design, the MSU can be used in various ways: in classic separation mode, in bedding mode (production of bedding material) or in combined mode, which allows switching between the two variants.

Options such as filtrate tank and filtrate pump, combined connections for feed and filtrate lines (DIN flange, Perrot coupling, square flange) as well as height-adjustable feet allow individual adaptation to the conditions on site.

### MOBILE:

Easy transport

### EFFICIENT:

High separation and delivery performance with low energy consumption and wear

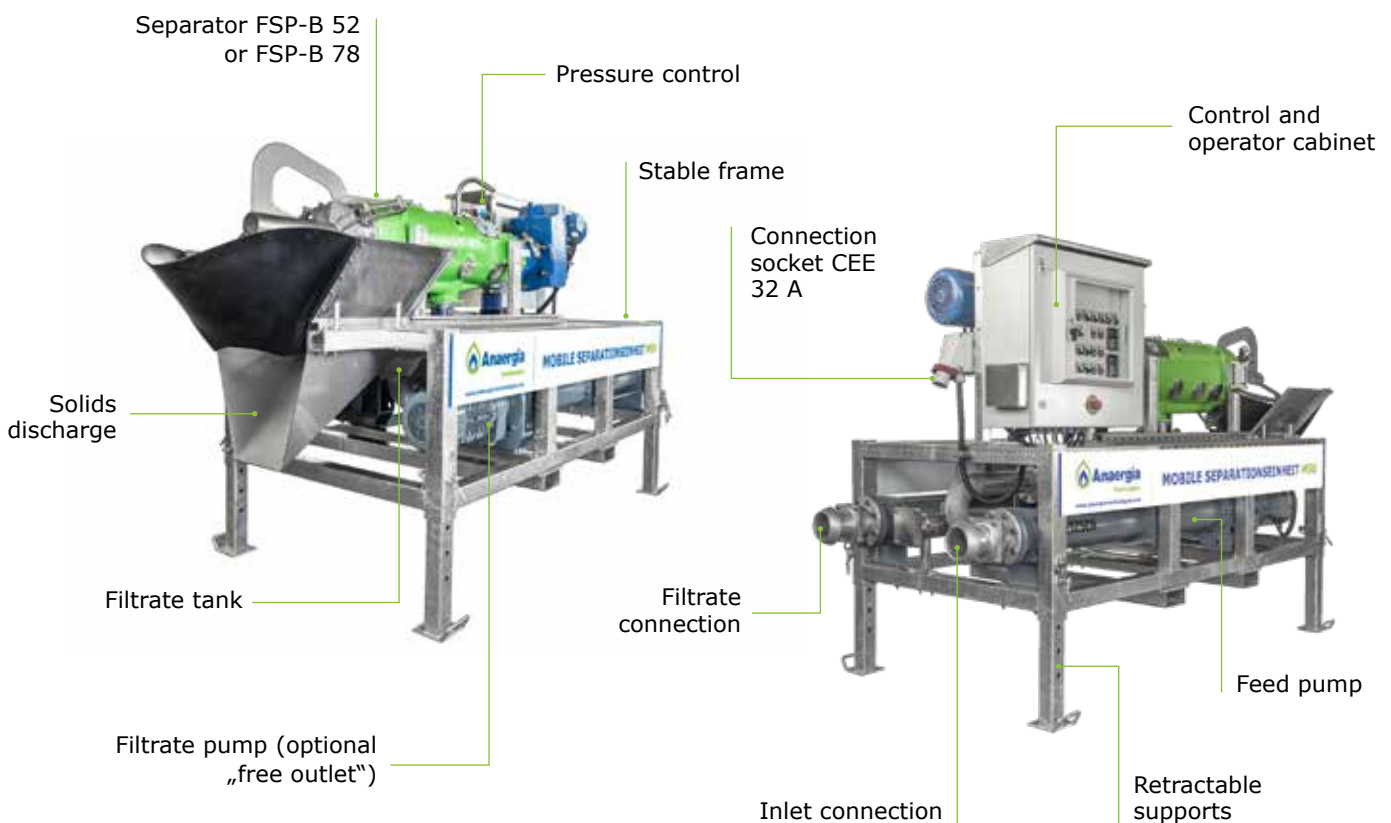

### ROBUST:

Galvanized steel frame, stable pipe construction, solid components

### INTELLIGENT:

Integrated control for uncomplicated operation

### FLEXIBLE:

Uncomplicated adaptation to different operating locations



# MSU PRO - MOBILE SEPARATION „ADVANCED“

DRIVE UP, CONNECT AND GO

The MSU Pro is an extension of the MSU. The additional conveyor belt with a length of 6 m can be swiveled up to 180°. With a drop height of 4 m, the MSU Pro is even more flexible in use than the MSU.

A level sensor on the receiving hopper of the conveyor belt provides additional operational safety. It shuts down the system in the event of a plug breakthrough/liquid leakage at the separator.

COMPONENTS	MSU	MSU PRO
<b>Self-supporting base frame with mounting for forklift tines</b>	Galvanized	Stainless steel
<b>Pipelines</b>	Galvanized	Stainless steel
<b>Separator</b>	All separators from the program	FSP B-78/15 line also as bedding
<b>Dosing pump</b>	Progressive cavity pump 10 - 28 m <sup>3</sup> /h	Progressive cavity pump 15 - 37 m <sup>3</sup> /h
<b>Filtrate pump</b>	Progressive cavity pump or RPM3000	Progressive cavity pump 15 - 37 m <sup>3</sup> /h
<b>Prepared for mounting on trailer</b>	no	yes
<b>Feet for height adjustment available</b>	yes	no
<b>Free outlet filtrate pipe</b>	optional	yes
<b>Conveyor belt, swivelling, length 6 m, Conveyor belt swivelling &gt;180°, Transfer height 4 m when mounted on a trailer (platform height approx. 0.7 m)</b>	no	yes
<b>Additional leak protection</b>	no	yes
<b>Cutting filter for contaminant removal</b>	no	optional
<b>Flowmeter</b>	optional	optional
<b>Remote access module</b>	no	optional
<b>Visualisation on the control cabinet</b>	no	yes
<b>Power connection 32 A</b>	yes	yes

## OUR ANAERGIA TECHNOLOGIES

We offer solutions for the following applications:

- » Pump Technology
- » Mixing Technology
- » Separation
- » Extrusion Technology
- » Screening & Sorting
- » Size Reduction
- » Organic Polishing
- » Conveyor Technology



### Anaergia Technologies GmbH

Oestinghausener Str. 12 · D-59510 Lippetal  
Fon: (+49) 2923 / 610 940

[www.anaergia-technologies.com](http://www.anaergia-technologies.com)



## SERVICE BOX CLASSIC

SAFE OPERATION AND EASY MAINTENANCE  
IN BIOGAS PLANTS, WASTEWATER TREATMENT FACILITIES  
AND INDUSTRIAL APPLICATIONS



# BENEFITS AT A GLANCE

SAFE - RELIABLE - MAINTENANCE FRIENDLY

With our Service Boxes for anaerobic digesters and feed-stock storage tanks with concrete or membrane roofs, operation of mixers is child's play. Rotating the mixer to the left and right or adjusting the height is done from outside the tank, thanks to the height adjustment winch.

The position and angle of the mixer can be inspected at any time with the integrated viewing window. The optional integrated over/underpressure safety device provides reliable protection of the tank.

In addition, use of the Service Box Classic patented gas

lock seal enables safe digester maintenance without methane emissions. General mixer maintenance can be completed on-site by lifting the mixer until it is inside the Service Box and, after removal of the front lid, rotating it to the outside.

For larger maintenance tasks or in case of replacement, mixers can be completely removed. All of this is possible without lowering the level of the tank or even opening the membrane roof. As a result, there is minimal or no impact on the biological process. That saves money and, of course, valuable time.

## EFFICIENT:

Extended operating times with quick access for maintenance tasks

## FLEXIBLE:

Suitable for tanks with concrete or membrane roofs and for mixers with diameters of up to Ø940mm (37inch)



## SAFE:

Over/underpressure safety device for up to 5mbar overpressure and -1.3mbar underpressure

## INTELLIGENT:

Adjustment unit for operation of mixers and inspection through viewing window

## ROBUST:

Robust stainless steel design

# YOUR SPECIALIST FOR SERVICE AND SAFETY

## SERVICE BOX CLASSIC



### EXPERIENCE FLEXIBILITY

- » Use of mixers from various manufacturers with a propeller diameter of up to 940mm
- » Installation in tanks with concrete roofs or even with membrane roofs (17° to 35° angle) possible

### UNCOMPROMISING SAFETY

- » Integrated and frost-proof over/underpressure safety device for up to 5mbar overpressure and -1.3mbar underpressure
- » Integrated biogas connection flange
- » Spare instrument connections
- » Standard biogas component certified by the German TÜV-SÜD

### MAXIMIZE DIGESTER ACTIVE VOLUME

- » Maximum active tank volume thanks to the simple adjustment of the mixer height and attack angle via the height adjustment device

### QUICKER AND EASIER MAINTENANCE

- » Two service openings for smaller and larger maintenance tasks provide quick access while maintaining safety
- » Minimize biogas loss
- » Integrated viewing glass for quick inspection of the tank interior



Service Box with installation frame

Service Box for membrane roof with 35° angle

# OUR EXTRAS

FOR EVEN GREATER COMFORT

There are various attachments and accessories available for the Service Box Classic. They can be optionally configured individually or as a package.

## WORK PLATFORM:

Offers even more room for assembly and maintenance tasks on membrane roof installations. Handrails are provided for additional safety.



## WINCH CABLE:

Winch cable between mixer and height adjustment device made of stainless steel or marine grade polymers



## SQUARE GUIDE PIPE:

Guides the mixer in the tank



## OVERPRESSURE/UNDERPRESSURE SAFETY DEVICE:

Combined vertical box for integrated, frost-proof over/underpressure safety device



## FLOOR BEARING AND ELEVATED TRIPODS:

Floor bearing for guiding the square guide pipe on the tank floor



Floor bearing



Elevated tripods available in 0.5m and 1m (20inch and 40inch) risers

## HEIGHT ADJUSTMENT WINCH:

Reposition the mixer height and angle using the external winch and positioning device. Gear ratios allow for installation of mixers up to 350kg (770lbs).



# SERVICE BOX CLASSIC TYPICAL INSTALLATION

RETROFITS MADE EASY

---

The Service Box Classic is ideal for installations in all anaerobic digesters and feedstock conditioning tanks with solid concrete and steel roofs and even direct integration into membrane roofs. The standard square pipe has a cross-section of 150 x 150mm (6inch x 6inch) and can be delivered in lengths of up to 12m (40feet). This makes it possible to integrate the Service Box Classic into a wide range of biogas plants or wastewater treatment plant anaerobic digesters.

Hundreds of plants in Europe and around the world already benefit from the advantages of the Service Box. These benefits include the integrated over/underpressure safety device and the convenient service opening for mixer maintenance and recovery without biogas discharge or hazardous tank entry.

As an alternative to our Service Box Classic, our Service Box Pro offers even greater comfort for assembly and maintenance tasks with more space and better accessibility to the mixer.

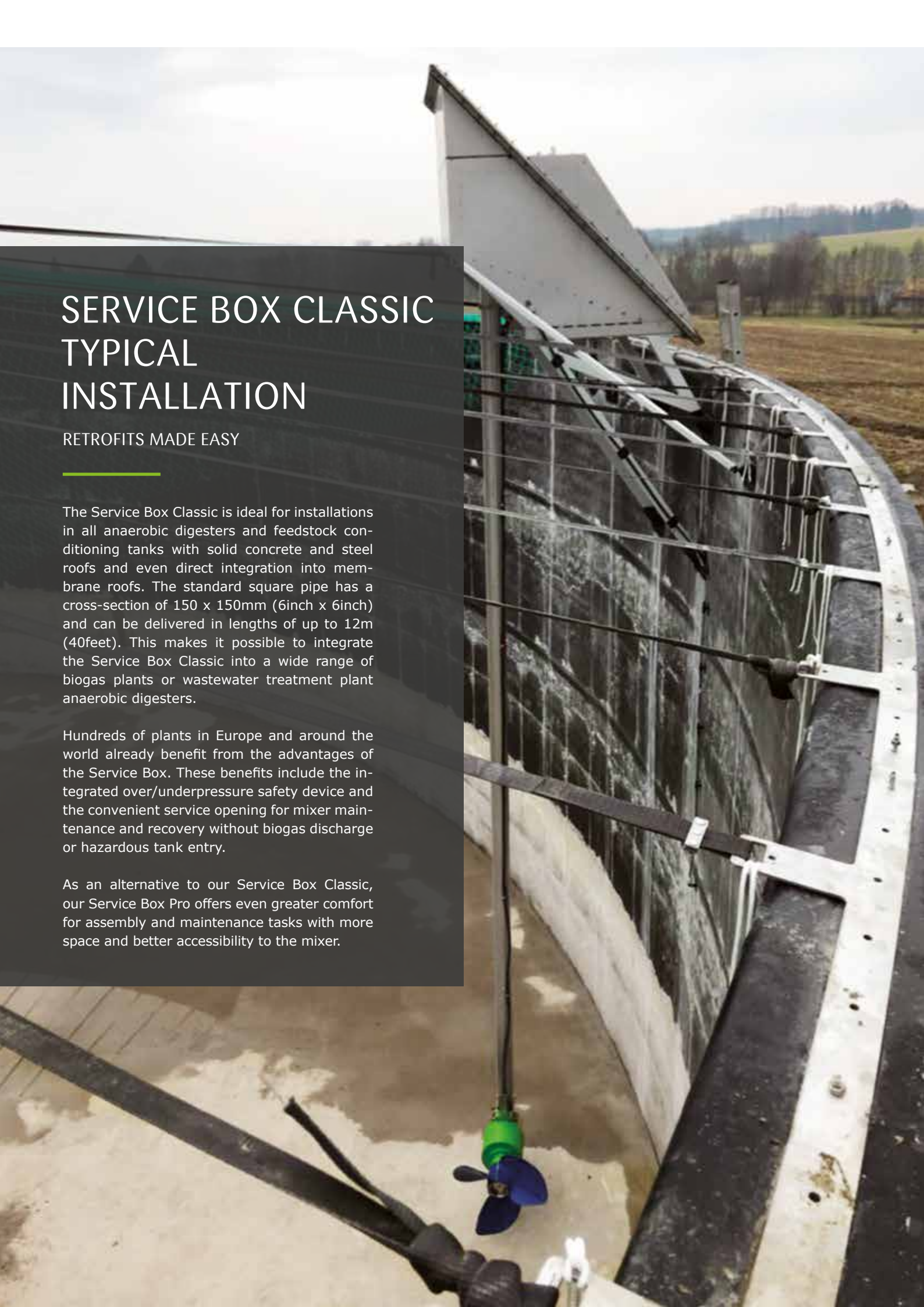

## OUR ANAERGIA TECHNOLOGIES

We offer solutions for the following applications:

- » Pump Technology
- » Mixing Technology
- » Separation
- » Extrusion Technology
- » Screening & Sorting
- » Size Reduction
- » Organic Polishing
- » Conveyor Technology



**Anaergia Inc.**  
**Headquarters**  
 Burlington, Ontario,  
 Canada  
 T: +1 905-766-3333

**Anaergia UK Ltd.**  
**Sales Office**  
 St. Neots, Cambs,  
 United Kingdom  
 T: +44 1480-477-608

**DB Technologies BV**  
**Product Company**  
 Oldenzaal, Netherlands  
 T: +31 541-745031

**Anaergia Technologies GmbH**  
**Product Company**  
 Lippetal, Germany  
 T: +49 2923-610940

**Anaergia OREX**  
**Manufacturing s.r.l.**  
**Product Company**  
 Ovada, Italy  
 T: +39 0143-835665

**Anaergia s.r.l.**  
**Sales Office**  
 Treviglio, Italy  
 T: +39 0363-1970144

**Anaergia Services, LLC**  
**Sales Office**  
 Carlsbad, California,  
 United States  
 T: +1 760-436-8870

**Anaergia Africa (Pty) Ltd.**  
**Sales Office**  
 Cape Town, South Africa  
 T: +27 73 093 8328

**Anaergia Singapore Pte. Ltd.**  
**Sales Office**  
 Singapore  
 T: +65 6316-1575

### Anaergia Technologies GmbH

Oestinghausener Str. 12 · D-59510 Lippetal  
 T: (+49) 2923 / 610 940  
 www.anaergia-technologies.com

[info@anaergia.com](mailto:info@anaergia.com)

[www.anaergia.com](http://www.anaergia.com)



## SERVICE BOX PRO

**SAFE OPERATION AND EASY MAINTENANCE  
IN BIOGAS PLANTS, WASTEWATER TREATMENT FACILITIES  
AND INDUSTRIAL APPLICATIONS**



# BENEFITS AT A GLANCE

SAFE - RELIABLE - MAINTENANCE FRIENDLY

With our Service Box Pro for anaerobic digesters and feedstock storage tanks with concrete or membrane roofs, operation of mixers is child's play.

Rotating the mixer to the left and right or adjusting the height is done from outside the tank, thanks to the height adjustment winch.

The position and angle of the mixer can be inspected at any time with the integrated viewing window. The optionally integrated over/underpressure safety device provides reliable protection of the tank.

In addition, use of the Service Box Pro patented gas lock seal enables safe digester maintenance with low methane emissions.

General mixer maintenance can be completed on the Service Box platform thanks to the removable floor panel. For larger maintenance tasks or in case of replacement, mixers can be completely removed by simply loosening clamping bolts. All of this is possible without lowering the level of the tank or even opening the membrane roof. As a result, there is minimal or no impact on the biological process. That saves money and, of course, valuable time.

## EFFICIENT:

Extended operating times with quick access for maintenance tasks

## FLEXIBLE:

Suitable for tanks with concrete or membrane roof and for mixers with diameters of up to Ø1500mm (59inches)



## SAFE:

Over/underpressure safety device for up to 5mbar overpressure and -1.3mbar underpressure

## INTELLIGENT:

Adjustment unit for operation of mixers and inspection through viewing window

## ROBUST:

Robust stainless steel design

# YOUR SPECIALIST FOR SERVICE AND SAFETY

## SERVICE BOX PRO



### EXPERIENCE FLEXIBILITY

- » Use of mixers from various manufactures with a propeller diameter of up to 1500mm
- » Installation in tanks with concrete roofs or even with membrane roofs (20° to 45° angle up to ¼ sphere) possible

### UNCOMPROMISING SAFETY

- » Integrated and frost-proof over/underpressure safety device for up to 5mbar overpressure and -1.3mbar underpressure
- » Integrated biogas connection flange
- » Spare instrument connections
- » Standard biogas component certified by the German TÜV-SÜD

### MAXIMIZE DIGESTER ACTIVE VOLUME

- » Maximum active tank volume thanks to the simple adjustment of the mixer height and attack angle via the height adjustment device

### QUICKER AND EASIER MAINTENANCE

- » Two service openings for smaller and larger maintenance tasks provide quick access while maintaining safety
- » Minimize biogas loss
- » Integrated viewing glass for quick inspection of the tank interior



Service Box with installation frame



Service Box for membrane roof with 20° angle

# OUR EXTRAS

FOR EVEN GREATER COMFORT

There are various attachments and accessories available for the Service Box Pro. They can be optionally configured individually or as a package.

## WORK PLATFORM:

Offers even more room for assembly and maintenance tasks on membrane roof installations. Handrails are provided for additional safety.



## WINCH CABLE:

Winch cable between mixer and height adjustment device made of stainless steel or marine grade polymers



## SQUARE GUIDE PIPE:

Guides the mixer in the tank



## OVERPRESSURE/UNDERPRESSURE SAFETY DEVICE:

Integrated, frost-proof over/underpressure safety device

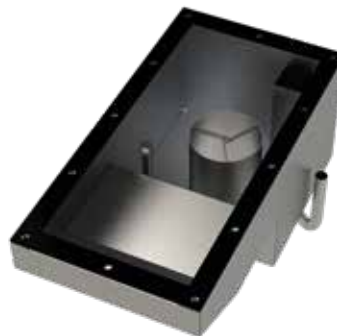

Overpressure safety device



Underpressure safety device

## FLOOR BEARING AND ELEVATED TRIPODS:

Floor bearing for guiding the square guide pipe on the tank floor



Floor bearing



Elevated tripods available in 0.5m and 1m (20inch and 40inch) risers

## HEIGHT ADJUSTMENT WINCH:

Reposition the mixer height and angle using the external winch and positioning device. Gear ratios allow for installation of mixers up to 350kg (770lbs).



# SERVICE BOX PRO TYPICAL INSTALLATION

RETROFITS MADE EASY

---

The Service Box Pro is ideal for installations in all anaerobic digesters and feedstock conditioning tanks with solid concrete and steel roofs and even direct integration into membrane roofs. The standard square pipe has a cross-section of 150 x 150mm (6inch x 6inch) and can be delivered in lengths of up to 12m (40 feet). This makes it possible to integrate the Service Box Pro into a wide range of biogas plants or wastewater treatment plant anaerobic digesters.

Hundreds of plants in Europe and around the world already benefit from the advantages of the Service Box, including the integrated over/underpressure safety device and the convenient service opening for mixer maintenance and recovery without biogas discharge or hazardous tank entry.

## **Service Box Pro + PSM mixer:**

An ideal combination for your greenfield or retrofit project!

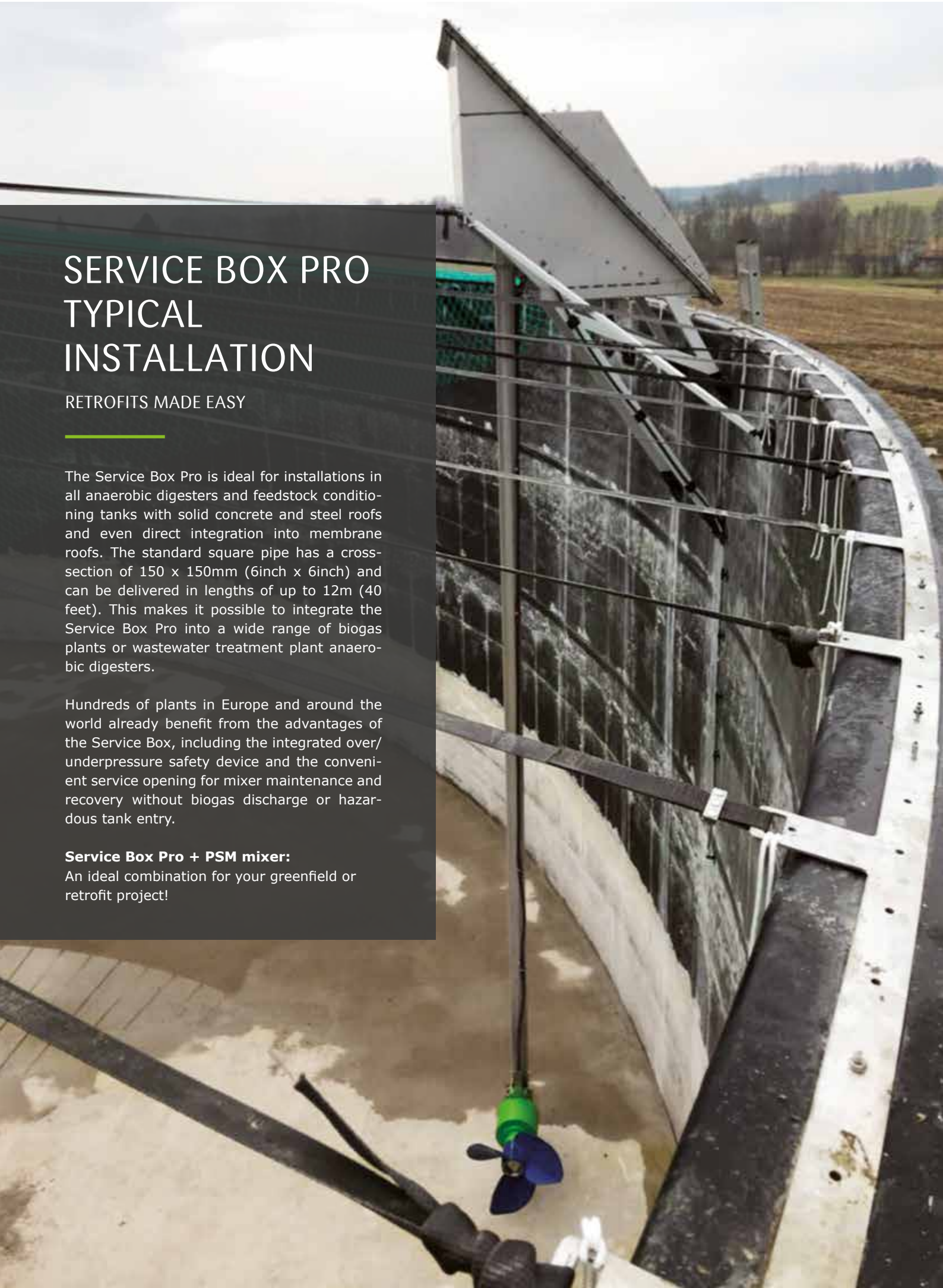

## OUR ANAERGIA TECHNOLOGIES

We offer solutions for the following applications:

- » Pump Technology
- » Mixing Technology
- » Separation
- » Extrusion Technology
- » Screening & Sorting
- » Size Reduction
- » Organic Polishing
- » Conveyor Technology



**Anaergia Inc.**  
**Headquarters**  
 Burlington, Ontario,  
 Canada  
 T: +1 905-766-3333

**Anaergia UK Ltd.**  
**Sales Office**  
 St. Neots, Cambs,  
 United Kingdom  
 T: +44 1480-477-608

**DB Technologies BV**  
**Product Company**  
 Oldenzaal, Netherlands  
 T: +31 541-745031

**Anaergia Technologies GmbH**  
**Product Company**  
 Lippetal, Germany  
 T: +49 2923-610940

**Anaergia OREX**  
**Manufacturing s.r.l.**  
**Product Company**  
 Ovada, Italy  
 T: +39 0143-835665

**Anaergia s.r.l.**  
**Sales Office**  
 Treviglio, Italy  
 T: +39 0363-1970144

**Anaergia Services, LLC**  
**Sales Office**  
 Carlsbad, California,  
 United States  
 T: +1 760-436-8870

**Anaergia Africa (Pty) Ltd.**  
**Sales Office**  
 Cape Town, South Africa  
 T: +27 73 093 8328

**Anaergia Singapore Pte. Ltd.**  
**Sales Office**  
 Singapore  
 T: +65 6316-1575

### Anaergia Technologies GmbH

Oestinghausener Str. 12 · D-59510 Lippetal  
 T: (+49) 2923 / 610 940  
 www.anaergia-technologies.com

[info@anaergia.com](mailto:info@anaergia.com)

[www.anaergia.com](http://www.anaergia.com)



# Feedrex®

Loading Station

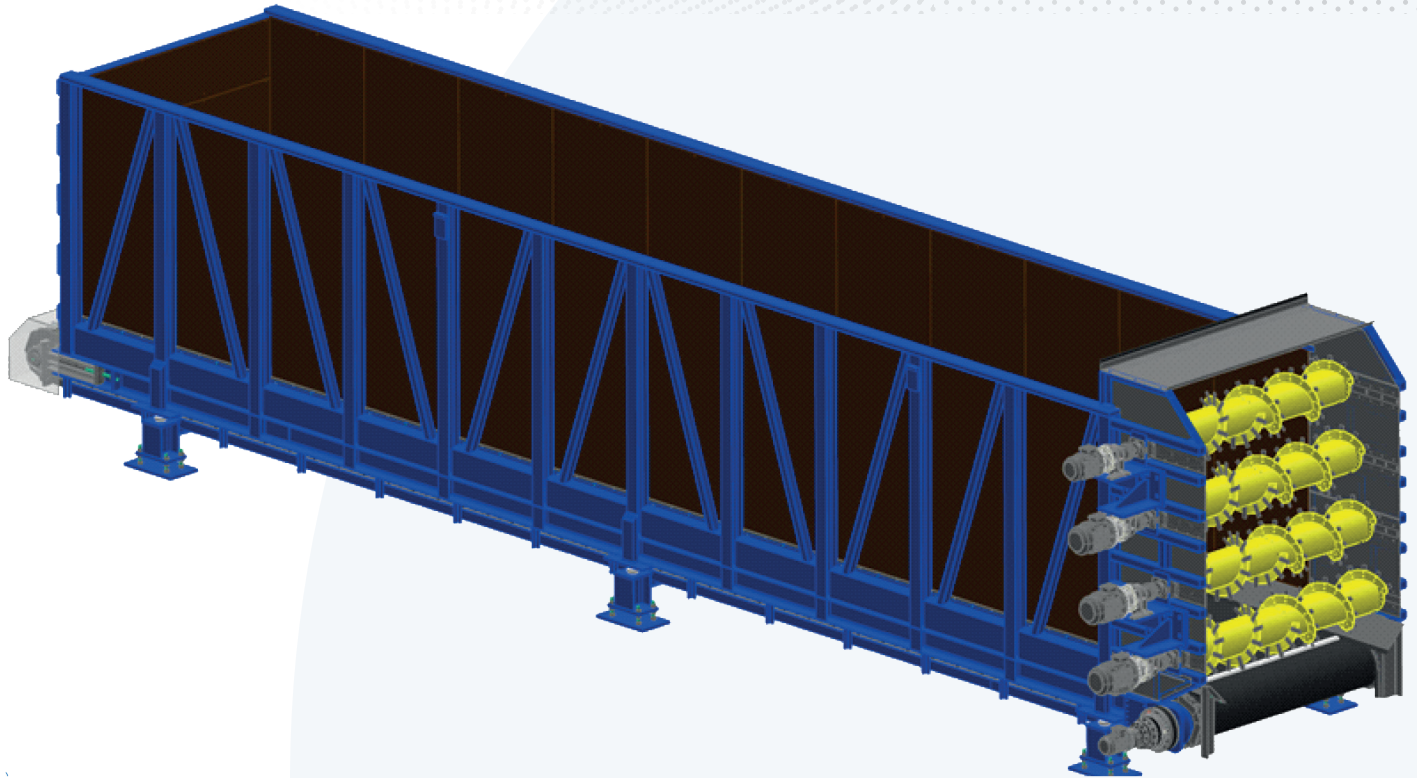

## Key Benefits

- Storage container volume 100 m<sup>3</sup>
- Independent motor milling drum
- Automatic chain lubrication system
- Weighting device
- Retractable roof
- Replaceable panels
- Removable rear wall



## Anaergia Solution

The solid feeder **Feedrex** is a system designed for the automatic and controlled feeding of solid biomass (such as silage, organic waste, and agricultural residues) into anaerobic digesters for biogas production. Its main function is to ensure a continuous and uniform substrate supply, avoiding overloads or shortages that could destabilize the biological process. Solid feeders are engineered to minimize energy consumption, reduce clogging risks, and provide high operational reliability. By enabling the processing of a wide range of heterogeneous biomasses, these systems optimize methane yield and help maintain stable and predictable process conditions. As a result, they play a crucial role in the efficiency and flexibility of modern biogas plants.



## Applications

- Automatic feeding of solid biomass into anaerobic digesters

TECHNICAL	UNIT	VALUE
Volume capacity	m <sup>3</sup>	100
Machine weight	ton	23
Installed power	kW	24
Power supply		3 phases + PE
<b>Electrical load</b>		
Belt conveyor	kW	0,55
Lower drum	kW	7,5
Central drum	kW	5,5
Central drum	kW	5,5
Upper drum	kW	4

# Riptor®

Bag Opening Technology



## Key Benefits

- **Opening rate of >98% for waste bags**
- Easy accessibility and maintenance
- Different working width
- Frequency-controlled drives with planetary gears
- Power consumption between 10 and 50 kW 8
- High Operational Control and Flexibility
- High efficiency ( 0.65 to 0.75 kWh/t)



INPUT MATERIAL



OUTPUT MATERIAL



## Anaergia Solution

**Riptor®:** in addition to its primary area of application, which is the opening and emptying of waste bags and small packages, our Riptor® can also be used in applications with large extraneous material in waste flows. Paper bales, tires, pallets, carpet and even box spring mattresses are shredded with ease.

**Improved Performance:** Riptor® offers operational control and flexibility. Easy maintenance includes the ability to get the inner rotor to cleaning and inspections



## Applications

With the high-quality, frequency-controlled drives and mechanically adjustable distance between the drum and the counter teeth of the front door, our Riptor® models can be optimally adapted to the input material. The Riptor®, therefore, is entirely flexible in terms of output, opening rate, and grain size of the output material

TECHNICAL DATA	RIPTOR 1800		RIPTOR 2500			RIPTOR 3000
	30	45	60	90	110	90
Working width	1800 mm		2500 mm			3000 mm
Inlet dimensions (LxW)	1150 x 1800 mm		1150 x 2500 mm			1150 x 3000 mm
Distance (drum and counter door teeth)	10 - 100 mm					
Length (outside)	2225 mm					
Width (outside)	3922 mm	5400 mm		5500 mm	5900 mm	
Discharge height	approx. 3800 mm					
Number of drivers	1		2			2
Total drive output	30 kW	45 kW	60 kW	90 kW	110 kW	90 kW
Power-Pack output (front door hydraulic unit)	1.5 kW					
Weight (excl. hopper and supports)	10.5 t	10.6 t	14 t	15 t	16 t	18 t
Speed range	5-14 rpm	8-21 rpm	8-22 rpm	13-35 rpm	16-43 rpm	13-35 rpm
Speed at 50 Hz	9 rpm	13 rpm	14 rpm	22 rpm	27 rpm	22 rpm
Min. opening rate (outer package ≥ 3L)	95%					
Max delivery rate	45 m³/h	63 m³/h	97 m³/h	148 m³/h	185 m³/h	179 m³/h
Delivery rate at density 350 kg/m³	16 t/h	22 t/h	34 t/h	52 t/h	65 t/h	62 t/h

# Plateo

Coarse Screening Technology



## Key Benefits

→ **Wide range of shaft sleeves for the cut size**

→ Speed frequency regulation

→ Low wear machine

→ Easy Operation and Maintenance

→ Energy efficient

→ Encapsulated design for maximum safety

→ Max installed power of 4 x 5.5 kW

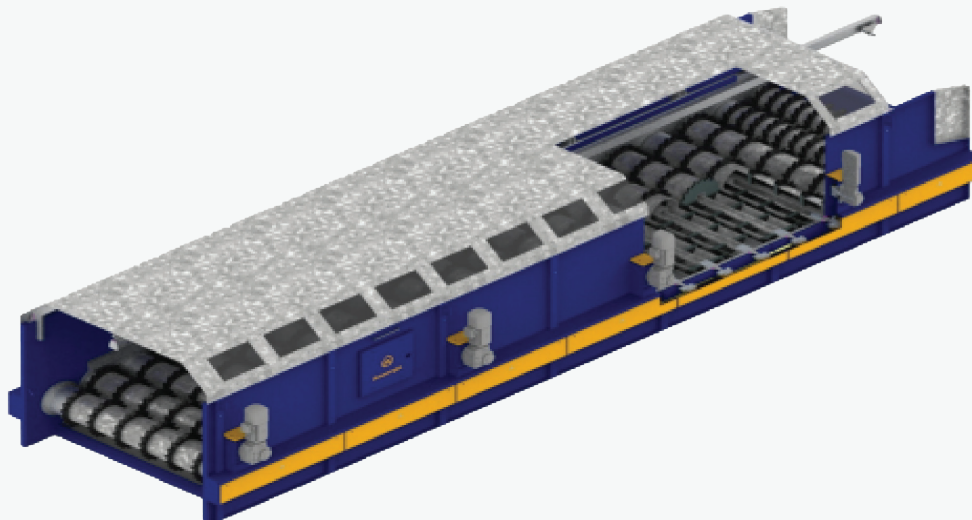

OUTPUT MATERIAL



## Anaergia Solution

**Plateo** is versatile and separates recyclable materials with cut sizes between 50 and 250mm. A torque limiter integrated in each shaft actively prevents blockages and material ragging. This design also counteracts damage to the shaft and drive system.

Depending on the model and the parameters of the input material, the PLATEO screen series delivers outputs in excess of 60t/h\*, measured on a bulk density of 350kg/m<sup>3</sup>.

The robust and innovative design of the screen deck guarantees fault-free, low-maintenance operation and long-lasting optimization of the separation result long-lasting optimization of the separation results.



## Applications

- Optimal adaptability to the material parameters provides the purest screen fractions
- Variation of the separation quality with the speed (frequency regulation)
- With the continuous feed of the output material, sorting results can be improved for the long-term
- Low operating costs due to reduced wear and efficient drives

TECHNICAL DATA	PLATEO 7000		PLATEO 9000	PLATEO 12000
	15	20	20	20
<b>Lenght</b> (screen-area)	7000 mm		9000 mm	10600 mm
<b>Working width</b>	1500 mm	2000 mm	2000 mm	2000 mm
<b>Width</b> (exterior; excl. drivers)	1980 mm	2480 mm		
<b>Design height</b>	2500 mm			
<b>Design height</b> (excl. cover)	2000 mm			
<b>Screen surface</b>	10.5 m <sup>2</sup>	14 m <sup>2</sup>	18 m <sup>2</sup>	23 m <sup>2</sup>
<b>Weight</b>	7.5 t	8 t	9 t	13 t
<b>Volume flow</b>	42 m <sup>3</sup> /h	57 m <sup>3</sup> /h	114 m <sup>3</sup> /h	170 rpm
<b>Capacity at 350 kg/m<sup>3</sup></b>	15 t/h	20 t/h	114 t/h	60 t/h
<b>Drive power</b>	2 x 5.5 kW		3 x 5.5 kW	4 x 5.5 kW

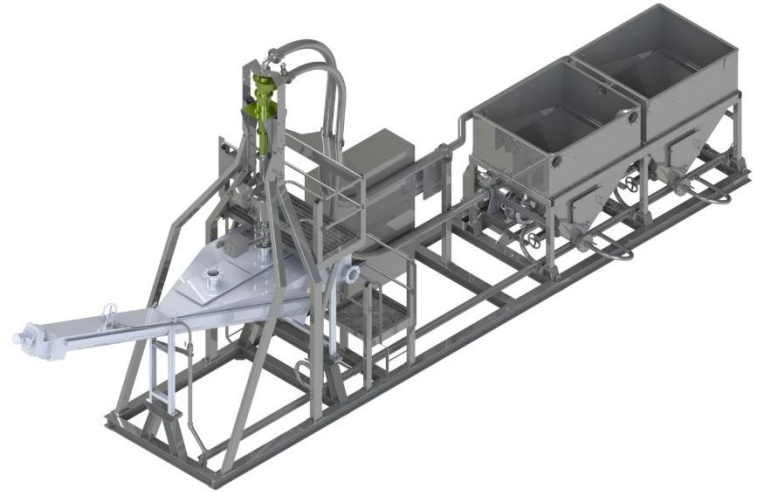

Anaergia's **GritREX** grit removal system removes Fast Settling Inorganic Solids (FSINS) contaminants from organic waste streams to prevent them from damaging downstream equipment and accumulating in digesters.

Organic slurry is received by the GritREX and converted into a clean, polished organic slurry and a grit reject solids stream. The GritREX first uses a hydrocyclone to separate grit from the organic slurry and then a grit classifier with a shaftless screw to wash the grit and maximize the recovery of organics. Complete with a sophisticated control system to ensure constant and smooth operation, the GritREX was designed with the operator in mind. This unit also has an operator platform for maintenance and valves for sampling and line flushing.

The GritREX is constructed on a skid, allowing the unit to be delivered fully assembled. This minimizes on-site construction and misalignment issues in the field. All GritREX units are fitted with identical instruments and pumps to reduce spare parts, costs, and storage space. These features provide GritREX users with a low-cost solution for industry leading grit removal.

## Advantages

- Maximizes digester capacity by preventing grit buildup
- Reduces wear of downstream pumps, mixers, pipes, centrifuges, valves, and instrumentation
- Delivered on a skid to minimize in-field construction, costs and time
- Effective grit removal with minimal reduction in organic stream biomethane potential

## Applications

The GritREX can remove grit contamination from a wide variety of waste streams that have been processed by different upstream equipment. Source feedstocks include:

- Municipal solid waste (MSW)
- Source separated organics (SSO)
- Municipal sludge
- Agricultural waste
- Sludge and agrifood mixtures

## Operation

Organic slurry is fed into the blending tank of the GritREX and is pumped to the hydrocyclone using a high wear centrifugal pump. At high velocity the centrifugal forces in the hydrocyclone separate the dense FSINS from the organic solids and slurry. The FSINS lean polished organic slurry exits the top of the hydrocyclone, is stored in the polish tank and is subsequently pumped further downstream to storage tanks or digesters. The FSINS rich slurry flows from the hydrocyclone to the grit classifier. FSINS settle to the bottom of the grit classifier which washes and dewateres the FSINS. The light organics that enter the grit classifier leave as part of the overflow stream and are recycled back to the blending tank. The washed and dewatered FSINS make up the reject stream and are collected in a bin for disposal.

1	Polish Tank	8	Hydrocyclone
2	Material Inlet	9	Operator Platform
3	Blending Tank	10	Grit Pot
4	HC Overflow Outlet	11	Grit Classifier Shaftless Screw
5	Polished Stream Outlet with Flow Meter	12	Control Panel
6	Pump 1	13	Maintenance Platform
7	Pump 2	14	Flow Indicator Transmitter

<b>A</b>	2.24 m
<b>B</b>	13.69 m
<b>C</b>	5.91 m
<b>D</b>	2.93 m
<b>Weight</b>	

<b>Feed</b>	Up to 15 %TS
<b>Capacity</b>	Up to 4 dry tonnes/hr
<b>Output</b>	Polished Slurry: 10-15% TS Reject: > 60 %TS

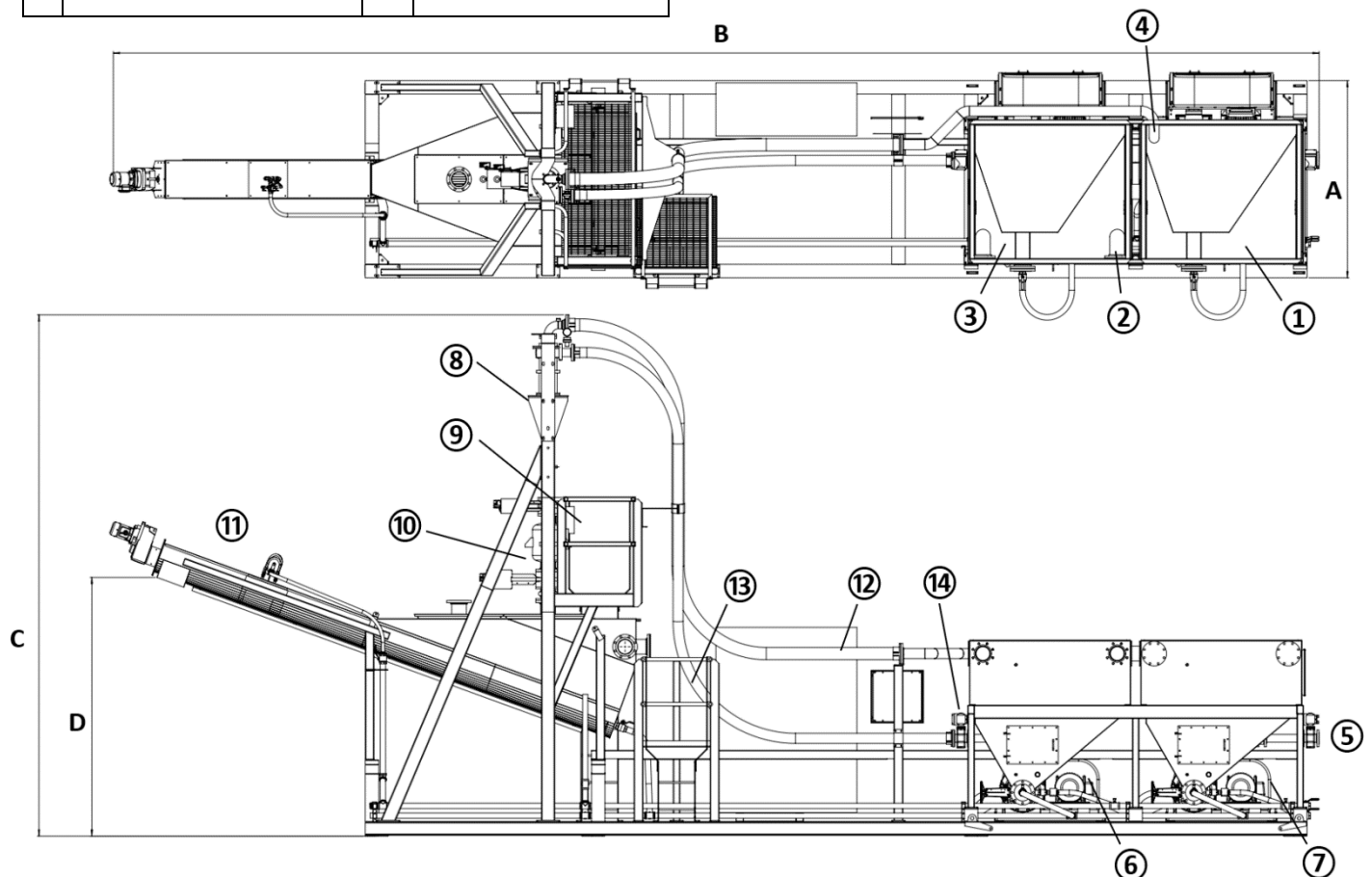

Unit Specifications			
<b>Power Supply</b>	<ul style="list-style-type: none"> <li>• 400 VAC/ 3 / 50 Hz</li> <li>• 480 VAC/ 3 / 60Hz</li> </ul>	<b>Feed Source</b>	<ul style="list-style-type: none"> <li>• Flowable organic slurry</li> </ul>
<b>Connected Power</b>	<ul style="list-style-type: none"> <li>• 61 kW, 81 hp</li> <li>• 1.35 kWh/m<sup>3</sup> of wet slurry</li> </ul>	<b>Capacity</b>	<ul style="list-style-type: none"> <li>• Up to 15% TS</li> <li>• 4 dry tonnes/hr</li> </ul>
<b>Control System</b>	<ul style="list-style-type: none"> <li>• Local control at panel via HMI Siemens 7" Touch panel</li> <li>• Remote control via SCADA</li> <li>• Siemens PLC 1513</li> <li>• IP66</li> <li>• VFD Profinet control</li> </ul>	<b>Polished Slurry</b>	<ul style="list-style-type: none"> <li>• Up to 45 m<sup>3</sup>/hr</li> <li>• &lt;15% TS</li> </ul>
		<b>Wash Water</b>	<ul style="list-style-type: none"> <li>• Supply: Clean Water, Filtrate &amp; Permeate</li> <li>• Consumption: Application Dependent</li> </ul>

## Features

- Cyclone sized for every application to maximize removal of FSINS
- Stainless steel tanks, grit classifier, pipes and valves for high corrosion resistance
- Hot-dip galvanized carbon steel frame and platform for durability and corrosion resistance
- Fully automated system with instrumentation (level transmitter, level switch, flowmeter and pressure transmitter) for process control, remote process monitoring and support
- Flexible rubber hose for easy operation, reduced wear and rapid installation
- VFD controlled heavy duty, wear resistant, centrifugal recessed impeller vortex pumps for reduced wear in highly abrasive applications
- Rubber lined, wear resistant hydrocyclone designed for aggressive and abrasive slurries
- Shaftless screw conveyors with HARDOX liners for abrasive applications
- Operator friendly design with a platform for easy access to the hydrocyclone and grit classifier for hassle free maintenance
- Built-in stainless-steel flush water system for pipe and tank flushing to prevent FSINS build up and minimize maintenance, with a single tie in connection point for customers
- Valves for sampling, line draining, tank isolation and cleaning during maintenance

# Cleanrex 3000H<sup>®</sup>

Rotating Hammer Separation Technology

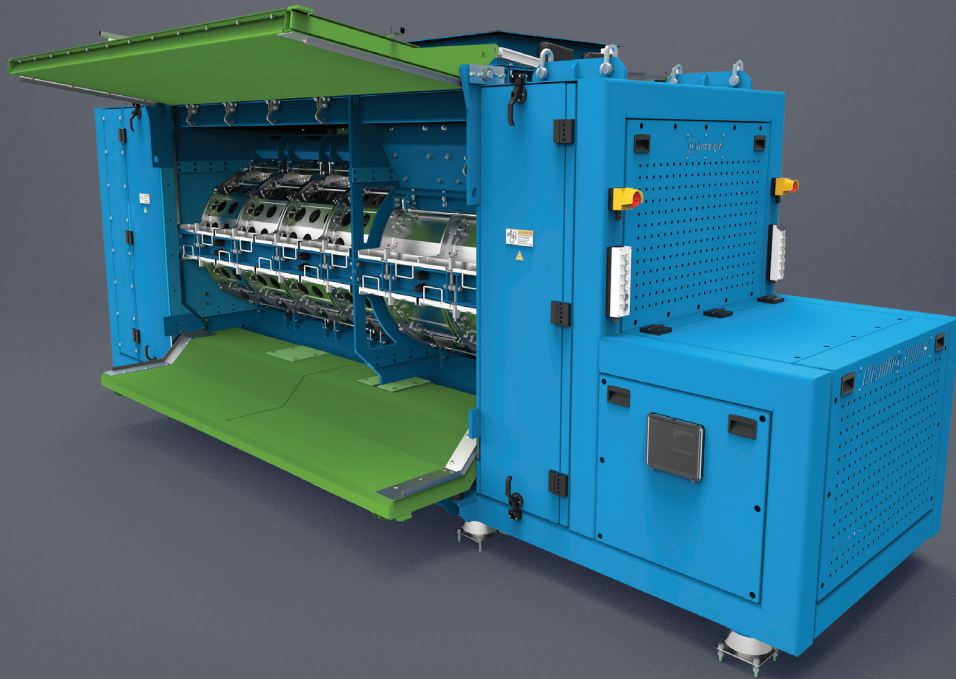

## Key Benefits

→ **High uptime**

→ Low Opex due to smart part design

→ Cost effective solution for organic separation

→ High performance to cost ratio

→ Rejects material consisting of 90% plastics

→ Organic material consisting of less than 2% inorganic material

→ Reduction of cleaning time due to machine self-cleaning feature



INCOMING SSO



WET FRACTION



REJECTS



## Anaergia Solution

Anaergia's **CleanREX 3000-H** separates inorganic materials such as plastic, paper, metals, glass, stones and other inorganic materials from the waste stream. The CleanREX 3000-H uses novel technology to split the waste stream into reject and organic fractions. An internal fast spinning rotor with specially designed hammers splits and smashes the raw waste material against the screens. The hammers increase operational capacity while effectively extracting valuable organic material from the waste stream. A series of water nozzles mounted in the inlet and to the casing surrounding the screen provide necessary dilution and/or cleaning water to the inbound waste material and clean any buildup of material off the screens.



## Applications

- Polishing of contaminated organic waste like SSO/ FORSU and lightly contaminated MSW
- Removal of packaging and film plastics from food waste
- De-packing supermarket waste

TECHNICAL		UNIT	3000-75	3000-90	3000-110
Motor power	P	kW (Hp)	75 (100)	90 (120)	110 (148)
Net energy consumption	P <sub>n</sub>	kWh/ton	Range 4 - 7 average 5		
Weight	m	ton	10.5	10.6	10.7
Throughput (up to)	C	t/h	10	13	16
Density input material	p	kg/m <sup>3</sup>	Range 500 - 750 average 600 (at 30% TS and 15% contamination)		
machine lenght	L	mm (inch)	5815 (229)		
Machine width	W	mm (inch)	1720 (67)		
Machine height	H	mm (inch)	2338 (92)		
Screen lenght	W1	mm (inch)	3000 (118)		
Screen surface	A	m <sup>2</sup>	5,3 up tp 6,6		
Screen sizes	D	mm	8 / 10 / 12 / 16 / 20 / 25 / 30		
MCC panel		mm	1200 x 500 x 2000 (W x D x H)		
Drive	VFD controlled 6 pole e-motor with V-belt power trasmission				

# OREX 400

Organic Extrusion Press



## Key Benefits

- **Fully automated operation**
- Overload detection and protection
- MCC motor control cabinet with HMI display
- Hydraulic power pack with level sensor
- Automatic greasing system
- 120 kW average electric power consumption
- 9 to 15 t/h of material threaded



## Anaergia Solution

The **OREX** technology is a waste pressurizing technology that separates waste into two fundamental fractions. An organic wet fraction with hardly any non-organics and a solid dry fraction with almost no organic substances.

The separation technique consists of a chamber equipped with an extrusion matrix, and a moving ram. While the ram moves forward, the volume of the chamber decreases and the pressure rises. The moving ram compresses the waste in the chamber and the organics become more fluid due to the rising pressure. When the organics become more fluid, it can escape the high-pressure chamber through the extrusion matrix, leaving the solid waste behind.



## Applications

The OREX technology can be applied on a waste stream that contains a significant amount of organics. And these organics need to be separated for further processing. For example, the organics in municipal solid waste (MSW) or biowaste / source separated organics (SSO) contains a large amount of energy and has great potential for anaerobic digestion.

### Maximum capacity in metric ton / hour

	Feedstock density (kg/m <sup>3</sup> )				
	400	500	600	700	800
95%	10	13	16	16	16
90%	10	13	16	16	16
85%	10	13	16	16	16
80%	10	13	16	16	16
75%	10	13	16	16	16
70%	10	13	16	16	16
65%	10	13	14	14	14
60%	10	13	13	13	13

# OREX 500

Organic Extrusion Press



## Key Benefits

- **Fully automated operation**
- Overload detection and protection
- MCC motor control cabinet with HMI display
- Hydraulic power pack
- Automatic greasing system
- 170 kW average electric power consumption
- 10 to 15 t/h of material threated



## Anaergia Solution

The **OREX** technology is a waste pressurizing technology that separates waste into two fundamental fractions. An organic wet fraction with hardly any non-organics and a solid dry fraction with almost no organic substances.

The separation technique consists of a chamber equipped with an extrusion matrix, and a moving ram. While the ram moves forward, the volume of the chamber decreases and the pressure rises. The moving ram compresses the waste in the chamber and the organics become more fluid due to the rising pressure. When the organics become more fluid, it can escape the high-pressure chamber through the extrusion matrix, leaving the solid waste behind.



## Applications

The OREX technology can be applied on a waste stream that contains a significant amount of organics. And these organics need to be separated for further processing. For example, the organics in municipal solid waste (MSW) or biowaste / source separated organics (SSO) contains a large amount of energy and has great potential for anaerobic digestion.

### Maximum capacity in metric ton / hour

		Feedstock density (kg/m <sup>3</sup> )				
		400	500	600	700	800
Extruded fraction / yield	95%	15	18	20	20	20
	90%	15	18	20	20	20
	85%	15	18	20	20	20
	80%	15	18	20	20	20
	75%	15	18	20	20	20
	70%	15	18	20	20	20
	65%	15	18	19	19	19
	60%	15	17	17	17	17

# OREX 1000

Organic Extrusion Press

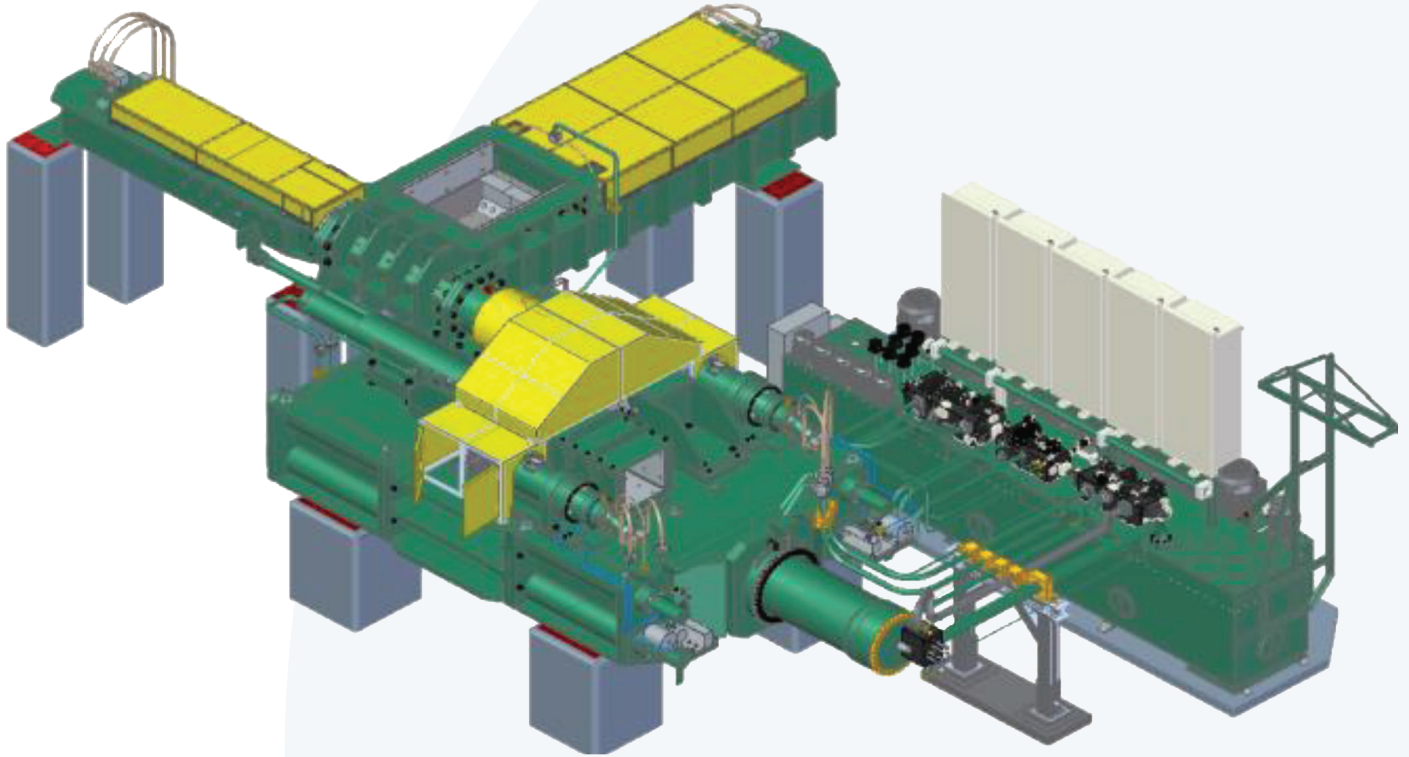

## Key Benefits

- **Fully automated operation**
- Overload detection and protection
- MCC motor control cabinet with HMI display
- Hydraulic power pack with level sensor
- Automatic greasing system
- 480 kW average electric power consumption
- 30 to 45 t/h of material threated



## Anaergia Solution

The **OREX** technology is a waste pressurizing technology that separates waste into two fundamental fractions. An organic wet fraction with hardly any non-organics and a solid dry fraction with almost no organic substances.

The separation technique consists of a chamber equipped with an extrusion matrix, and a moving ram. While the ram moves forward, the volume of the chamber decreases and the pressure rises. The moving ram compresses the waste in the chamber and the organics become more fluid due to the rising pressure. When the organics become more fluid, it can escape the high-pressure chamber through the extrusion matrix, leaving the solid waste behind.



## Applications

The OREX technology can be applied on a waste stream that contains a significant amount of organics. And these organics need to be separated for further processing. For example, the organics in municipal solid waste (MSW) or biowaste / source separated organics (SSO) contains a large amount of energy and has great potential for anaerobic digestion.

### Maximum capacity in metric ton / hour

		Feedstock density (kg/m <sup>3</sup> )				
		400	500	600	700	800
Extruded fraction / yield	95%	31	33	37	37	37
	90%	31	33	37	37	37
	85%	31	33	37	37	37
	80%	31	33	37	37	37
	75%	31	33	37	37	37
	70%	31	33	37	37	37
	65%	31	33	33	33	33
	60%	31	31	31	31	31